

## 170- $\mu$ Vrms ZERO-RIPPLE SWITCHED CAP BUCK-BOOST CONVERTER FOR VCO SUPPLY

### FEATURES

- **Wide Input Voltage Range:**
  - 1.8 V To 5.5 V for 2.7-V, 3-V, 3.3-V Output (TPS60240/2/3)
  - 2.7 V To 5.5 V for 5-V Output (TPS60241)
- **170- $\mu$ Vrms Zero Ripple Output:**
  - at 20 Hz to 10 MHz Bandwidth
- **Minimum Number of External Components**
  - No Inductors
  - Only Small Ceramic Chip Capacitors
- **Up to 90% Efficiency**
- **Regulated 3.3-V (TPS60240), 5-V (TPS60241), 3-V (TPS60243), and 2.7-V (TPS60242) Output Voltage With  $\pm 2.5\%$  Accuracy Over Load**
- **Up to 25-mA Output Current**
- **Shutdown Mode: 0.1  $\mu$ A Typical**
- **Thermal Protection and Current Limit**
- **Microsmall 8-Pin MSOP Package**
- **EVM Available TPS60241EVM-194**

- **Digital Cameras**
- **MP3 Players**
- **SIM Modules**
- **Electronic Games**
- **Memory Backup**
- **Handheld Meters**
- **Bias Supplies**

### DESCRIPTION

The TPS6024x is a switched capacitor voltage converter, ideally suited for VCO and PLL applications that require low noise and tight tolerances. Its dual-cap design uses four ceramic capacitors to provide ultralow output ripple yet high efficiency, while eliminating the need for inefficient linear regulators.

A wide input supply voltage range of 2.7 V to 5.5 V makes the TPS6024x ideal for lithium-based battery applications. The TPS60240/2/3 operates down to 1.8 V, supporting a 3.3-V, 2.7-V, 3-V output from two-cell, nickel- or alkaline-based chemistries. The devices work equally well for low EMI dc/dc step-up conversion without the need for an inductor. The high switching frequency (typical 160 kHz) promotes the use of small surface-mount capacitors, saving board space. The converter's shutdown mode conserves battery energy.

### APPLICATIONS

- **VCO and PLL Power for:**
  - PDA Phones
  - Cellular Phones
  - PCMCIA Modems
- **Smartcard Readers**

### typical application circuit

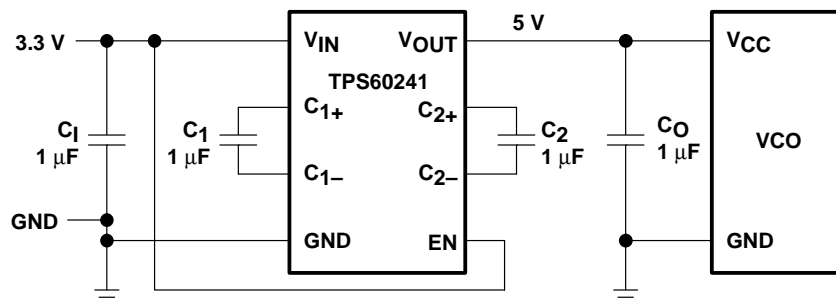

Please be aware that an important notice concerning availability, standard warranty, and use in critical applications of Texas Instruments semiconductor products and disclaimers thereto appears at the end of this data sheet.

# TPS60240, TPS60241 TPS60242, TPS60243

SLVS372B – JUNE 2001 – REVISED JANUARY 2002

## description(continued)

The devices are thermally protected and current-limited for reliable operation even under persisting fault conditions. Normal quiescent current (ground pin current) is only 250  $\mu\text{A}$ , and typically 0.1  $\mu\text{A}$  in shutdown mode. The TPS6024x devices come in a thin, 8-pin MSOP (DGK) package with a component height of only 1,1 mm.

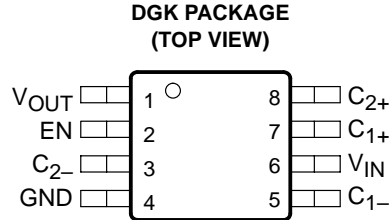

### AVAILABLE OPTIONS

| TA            | PART NUMBER† | PACKAGE MARKING | PACKAGE          | OUTPUT VOLTAGE (V) |
|---------------|--------------|-----------------|------------------|--------------------|
| -40°C to 85°C | TPS60241DGKR | AUB             | DGK (8-pin MSOP) | 5 V                |
| -40°C to 85°C | TPS60240DGKR | ATM             | DGK (8-pin MSOP) | 3.3 V              |
|               | TPS60242DGKR | AYF             | DGK (8-pin MSOP) | 2.7 V              |
|               | TPS60243DGKR | AYG             | DGK (8-pin MSOP) | 3 V                |

† This package type is available taped and reeled only. Quantity is 2500 units per reel (e.g., TPS60241DGKR). The devices are also available on mini reel with 250 units per reel. To order this packaging option, replace the R with a T in the part number (e.g., TPS60261DGKT).

functional block diagram

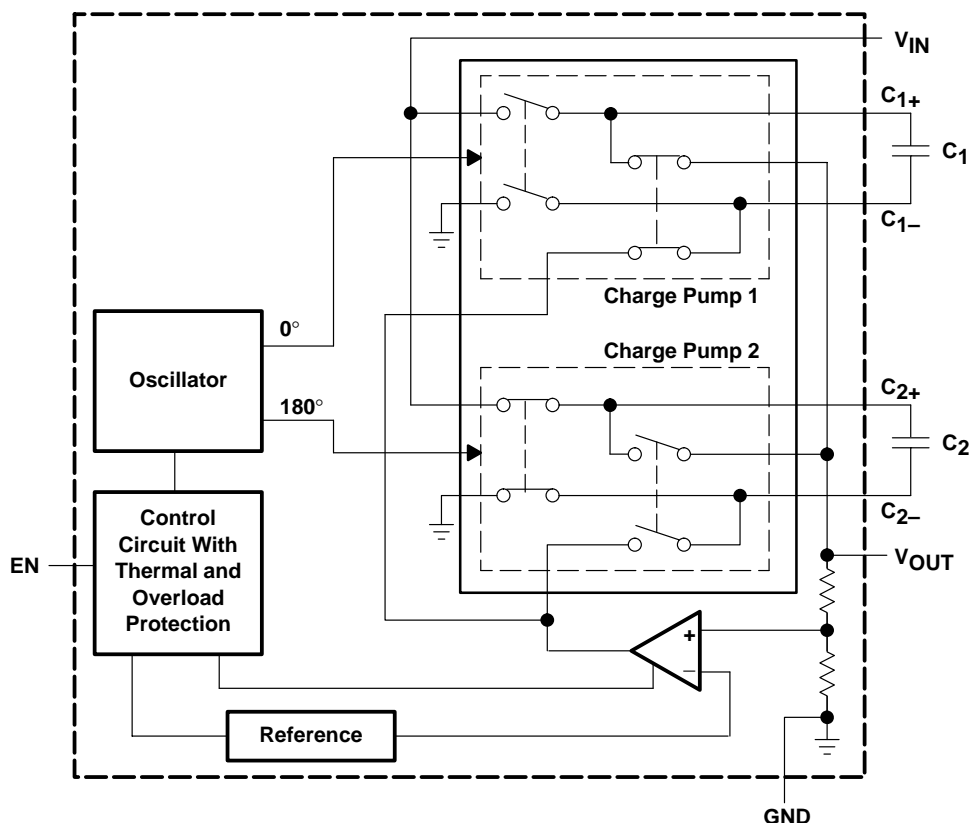

Terminal Functions

| TERMINAL NAME    | NO. | I/O | DESCRIPTION  |
|------------------|-----|-----|--|
| C <sub>1+</sub>  | 7   |     | Positive terminal of the flying capacitor C <sub>1</sub>   |
| C <sub>1-</sub>  | 5   |     | Negative terminal of the flying capacitor C <sub>1</sub>   |
| C <sub>2+</sub>  | 8   |     | Positive terminal of the flying capacitor C <sub>2</sub>   |
| C <sub>2-</sub>  | 3   |     | Negative terminal of the flying capacitor C <sub>2</sub>   |
| EN               | 2   | I   | Enable terminal, active high   |
| GND              | 4   |     | Ground   |
| V <sub>IN</sub>  | 6   | I   | Supply voltage input TPS60241: 2.7 V to 5.5 V, TPS60240/2/3: 1.8 V to 5.5 V. Bypass V <sub>IN</sub> to GND with a 1-μF external capacitor (C <sub>I</sub> ).   |
| V <sub>OUT</sub> | 1   | O   | Regulated power output. Bypass V <sub>OUT</sub> to GND with a 1-μF external filter capacitor (C <sub>O</sub> ). TPS60241: regulated 5-V output, TPS60240: regulated 3.3-V output, TPS60242: regulated 2.7-V output, TPS60243: regulated 3-V output |

**detailed description**

**operating principle**

The TPS6024x charge pump is a fixed-frequency, dual-phase charge pump that provides 25 mA of continuous supply current for low-noise applications such as VCOs used in cell phones and wireless appliances.

Low-noise operation results from using a proprietary dual-phase charge pump topology that relies on an operational amplifier in the feedback loop to reduce ripple. During the first phase, C<sub>1</sub> is charged to the supply voltage. Terminal C<sub>1+</sub> is connected to V<sub>IN</sub>, and C<sub>1-</sub> is connected to GND. In the second phase, C<sub>1-</sub> is connected to the output of the operational amplifier, and C<sub>1+</sub> is connected to V<sub>OUT</sub>. The operational amplifier then adjusts its output until the output V<sub>OUT</sub> delivers the correct voltage to make the resistor divided feedback point equal to the reference voltage. During this second phase, C<sub>2</sub> is charged to supply voltage. Terminal C<sub>2-</sub> is connected to GND, and C<sub>2+</sub> is connected to V<sub>IN</sub>. Phase one is then repeated with C<sub>2</sub>, now acting to provide charge to the output in place of C<sub>1</sub>, which is connected to the supply. The dual-phase operation lowers the output ripple voltage significantly compared to a standard single-phase charge pump. In addition, the linear feedback of the operational amplifier eliminates the ripple during discharge of the output capacitor (C<sub>O</sub>).

**shutdown**

Driving EN low disables the converter. This disables the internal circuits and reduces input current to typically 0.1 μA. In this mode, the load is disconnected from the supply voltage. The device exits shutdown once EN is set to a high level.

**start-up procedure**

The converter is enabled when EN is set from logic low to high. The start-up time to reach 90% of the nominal output voltage is typically 0.5 ms at load currents lower than 10 mA and with an output capacitor of 1 μF. Increasing the values of C<sub>O</sub> delays the start-up time.

**absolute maximum ratings over operating free-air temperature (unless otherwise noted)†**

|   |   |
|---|---|
| Supply voltage, V <sub>DD</sub> .....           | -0.3 V to 6 V   |
| Power dissipation, P <sub>D</sub> .....         | Internally limited  |
| Voltage EN .....                                | -0.3 V to 6 V   |
| Voltage C <sub>2-</sub> , C <sub>1-</sub> ..... | -0.3 V to V <sub>I</sub> or 5.5 V, whichever is lowest                    |
| Voltage C <sub>2+</sub> , C <sub>1+</sub> ..... | -0.3 V to V <sub>I</sub> , V <sub>O</sub> , or 5.5 V, whichever is lowest |
| Junction temperature, T <sub>J</sub> .....      | 125°C   |
| Storage temperature, T <sub>stg</sub> .....     | -65°C to 150°C  |
| Shortcircuit output current .....               | 80 mA maximum   |

† Stresses beyond those listed under “absolute maximum ratings” may cause permanent damage to the device. These are stress ratings only, and functional operation of the device at these or any other conditions beyond those indicated under “recommended operating conditions” is not implied. Exposure to absolute-maximum-rated conditions for extended periods may affect device reliability.

**DISSIPATION RATING TABLE**

| PACKAGE | T <sub>A</sub> ≤ 25°C<br>POWER RATING | DERATING FACTOR<br>ABOVE T <sub>A</sub> = 25°C | T <sub>A</sub> = 70°C<br>POWER RATING | T <sub>A</sub> = 85°C<br>POWER RATING |
|---------|---------------------------------------|--|---------------------------------------|---------------------------------------|
| DGK     | 376 mW                                | 3.76 mW/°C                                     | 207 mW                                | 150 mW                                |

NOTE: The thermal resistance junction to ambient of the DGK package is R<sub>TH-JA</sub> = 150°C/W.

**recommended operating conditions**

|                                 |                             | MIN                          | NOM | MAX | UNIT |    |
|---------------------------------|-----------------------------|------------------------------|-----|-----|------|----|
| V <sub>I</sub>                  | Input voltage range         | TPS60240, TPS60242, TPS60243 |     | 1.8 | 5.5  | V  |
|                                 |                             | TPS60241                     |     | 2.7 | 5.5  |    |
| I <sub>O</sub>                  | Output current range        | All devices                  |     |     | 25   | mA |
| C <sub>I</sub>                  | Input capacitor             |                              |     |     | 1    | μF |
| C <sub>1</sub> , C <sub>2</sub> | Flying capacitors           |                              |     |     | 1    | μF |
| C <sub>O</sub>                  | Output capacitor            |                              |     |     | 1    | μF |
| T <sub>A</sub>                  | Operating temperature range | -40                          |     | 85  | °C   |    |

**electrical characteristics for TPS6024X at T<sub>A</sub> = 25°C, C<sub>I</sub> = C<sub>O</sub> = 1 μF, C<sub>1</sub> = C<sub>2</sub> = 1 μF (unless otherwise noted), limits apply over the specified temperature range, -40°C to 85°C**

| PARAMETER         |                       | TEST CONDITIONS                          |               | MIN  | TYP | MAX    | UNIT |        |
|-------------------|-----------------------|--|---------------|--|-----|--------|------|--------|
| V <sub>I</sub>    | Input voltage         | TPS60240 Assured start-up                |               | I <sub>O</sub> ≤ 5 mA, R <sub>L</sub> = 600 Ω  |     | 1.8    | 5.5  | V      |
|                   |                       | TPS60241 Assured start-up                |               | I <sub>O</sub> ≤ 12 mA, R <sub>L</sub> = 417 Ω   |     | 2.7    | 5.5  |        |
|                   |                       | TPS60242 Assured start-up                |               | I <sub>O</sub> ≤ 12 mA, R <sub>L</sub> = 225 Ω   |     | 1.8    | 5.5  |        |
|                   |                       | TPS60243 Assured start-up                |               | I <sub>O</sub> ≤ 10 mA, R <sub>L</sub> = 300 Ω   |     | 1.8    | 5.5  |        |
| V <sub>O</sub>    | Output voltage        | TPS60240                                 |               | 1.8 V ≤ V <sub>I</sub> ≤ 5.5 V, 0 mA ≤ I <sub>O</sub> ≤ 5 mA   |     | 3.2175 | 3.3  | 3.3825 |
|                   |                       |  |               | 2.4 V ≤ V <sub>I</sub> ≤ 5.5 V, 0 mA ≤ I <sub>O</sub> ≤ 25 mA  |     |        |      |        |
|                   |                       | TPS60241                                 |               | 2.7 V ≤ V <sub>I</sub> ≤ 5.5 V, 0 mA ≤ I <sub>O</sub> ≤ 12 mA  |     | 4.875  | 5    | 5.125  |
|                   |                       |  |               | 3 V ≤ V <sub>I</sub> ≤ 5.5 V, 0 mA ≤ I <sub>O</sub> ≤ 25 mA  |     |        |      |        |
|                   |                       | TPS60242                                 |               | 1.8 V ≤ V <sub>I</sub> ≤ 5.5 V, 0 mA ≤ I <sub>O</sub> ≤ 12 mA  |     | 2.6325 | 2.7  | 2.7675 |
|                   |                       |  |               | 2.3 V ≤ V <sub>I</sub> ≤ 5.5 V, 0 mA ≤ I <sub>O</sub> ≤ 25 mA  |     |        |      |        |
|                   |                       | TPS60243                                 |               | 1.8 V ≤ V <sub>I</sub> ≤ 5.5 V, 0 mA ≤ I <sub>O</sub> ≤ 10 mA  |     | 2.925  | 3    | 3.075  |
|                   |                       |  |               | 2.3 V ≤ V <sub>I</sub> ≤ 5.5 V, 0 mA ≤ I <sub>O</sub> ≤ 25 mA  |     |        |      |        |
| I <sub>O</sub>    | Output current        | TPS60240/2/3                             | Nominal       | 2 V ≤ V <sub>I</sub> ≤ 5.5 V   |     | 12     |      |        |
|                   |                       |  | Short circuit | V <sub>I</sub> = 2 V   |     | 80     |      |        |
|                   |                       | TPS60241                                 | Nominal       | 2.7 V ≤ V <sub>I</sub> ≤ 5.5 V   |     | 12     |      |        |
|                   |                       |  | Short circuit | V <sub>I</sub> = 3.25 V  |     | 80     |      |        |
| f <sub>OSC</sub>  | Internal clock source |  | 100           | 160  | 220 | kHz    |      |        |
| V <sub>n</sub>    | Output noise voltage  | TPS60240/2/3                             |               | V <sub>I</sub> < 2.5 V, I <sub>O</sub> = 5 mA, ESR < 0.1 Ω, measured over 20 Hz to 10 MHz, C <sub>O</sub> = 4.7 μF |     | 170    |      |        |
|                   |                       | TPS60241                                 |               | V <sub>I</sub> = 2.7 V, I <sub>O</sub> = 5 mA, ESR < 0.1 Ω, measured over 20 Hz to 10 MHz, C <sub>O</sub> = 4.7 μF |     | 170    |      |        |
| V <sub>I(H)</sub> | EN                    | Logic high input voltage V <sub>OH</sub> |               | 1.3  |     | 5.5    | V    |        |
| V <sub>I(L)</sub> | EN                    | Logic low input voltage V <sub>OL</sub>  |               | -0.2   |     | 0.4    | V    |        |
| I <sub>I(H)</sub> | EN                    | Logic high input current                 |               |  |     | 100    | nA   |        |
| I <sub>I(L)</sub> | EN                    | Logic low input current                  |               |  |     | 100    | nA   |        |
| t <sub>(EN)</sub> | EN                    | Start-up time                            |               | V <sub>O</sub> > 90% of V <sub>(NOM)</sub><br>0.1 mA ≤ I <sub>O</sub> ≤ 10 mA, C <sub>O</sub> = 1 μF               |     | 0.5    |      |        |
| η                 | Efficiency            | TPS60240                                 |               | I <sub>O</sub> = 5 mA, V <sub>I</sub> = 1.8 V  |     | 89.6%  |      |        |
|                   |                       | TPS60241                                 |               | I <sub>O</sub> = 10 mA, V <sub>I</sub> = 2.7 V   |     | 90.8%  |      |        |
|                   |                       | TPS60242                                 |               | I <sub>O</sub> = 10 mA, V <sub>I</sub> = 1.8 V   |     | 73%    |      |        |
|                   |                       | TPS60243                                 |               | I <sub>O</sub> = 10 mA, V <sub>I</sub> = 1.8 V   |     | 81%    |      |        |

**TPS60240, TPS60241  
TPS60242, TPS60243**

SLVS372B – JUNE 2001 – REVISED JANUARY 2002

**electrical characteristics for TPS6024X at  $T_A = 25^\circ\text{C}$ ,  $C_1 = C_O = 1\ \mu\text{F}$ ,  $C_1 = C_2 = 1\ \mu\text{F}$  (unless otherwise noted), limits apply over the specified temperature range,  $-40^\circ\text{C}$  to  $85^\circ\text{C}$  (continued)**

| PARAMETER        |                         | TEST CONDITIONS                            | MIN | TYP | MAX | UNIT             |
|------------------|-------------------------|--|-----|-----|-----|------------------|
| $I_Q$            | Quiescent current       | $I_O = 0\ \text{mA}$ , $V_I = 3\ \text{V}$ |     | 250 | 325 | $\mu\text{A}$    |
|                  |                         | In shutdown mode                           |     | 0.1 | 1   |                  |
| Thermal shutdown | Temperature activated   |  |     | 160 |     | $^\circ\text{C}$ |
|                  | Temperature deactivated |  |     | 140 |     |                  |

**TYPICAL CHARACTERISTICS**

**Table of Graphs**

|                              |                         | FIGURE |
|------------------------------|-------------------------|--------|
| Efficiency                   | vs Input voltage        | 1–4    |
|                              | vs Output current       | 5–8    |
| $V_O$ Output voltage         | vs Input voltage        | 9–12   |
|                              | vs Output current       | 13–16  |
|                              | vs Free-air temperature | 17     |
| Quiescent current            | vs Input voltage        | 18     |
|                              | vs Free-air temperature | 19     |
| $I_{L(sd)}$ Shutdown current | vs Free-air temperature | 20     |
| $V_n$ Output noise voltage   | vs Output current       | 21     |
| Maximum output current       | vs Input voltage        | 22–25  |
| Load transient response      |                         | 26     |
| Start-up timing              |                         | 27     |
| Line transient response      |                         | 28     |
| Noise voltage spectrum       |                         | 29     |
| Output voltage ripple        | vs Time                 | 30     |

TYPICAL CHARACTERISTICS

TPS60240  
EFFICIENCY  
VS  
INPUT VOLTAGE

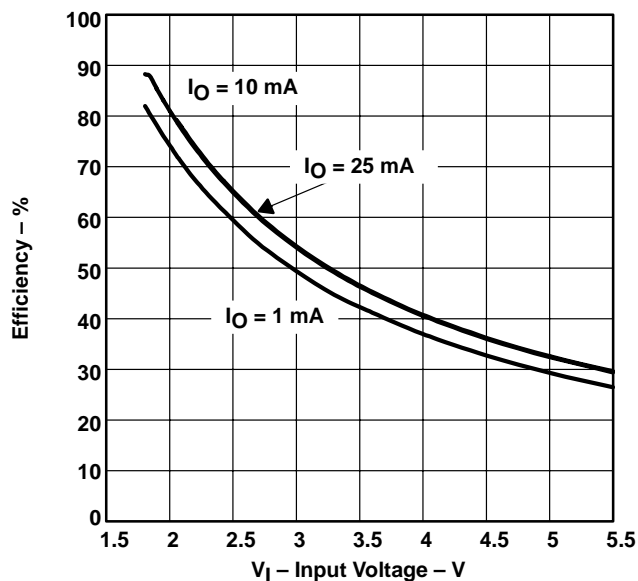

Figure 1

TPS60241  
EFFICIENCY  
VS  
INPUT VOLTAGE

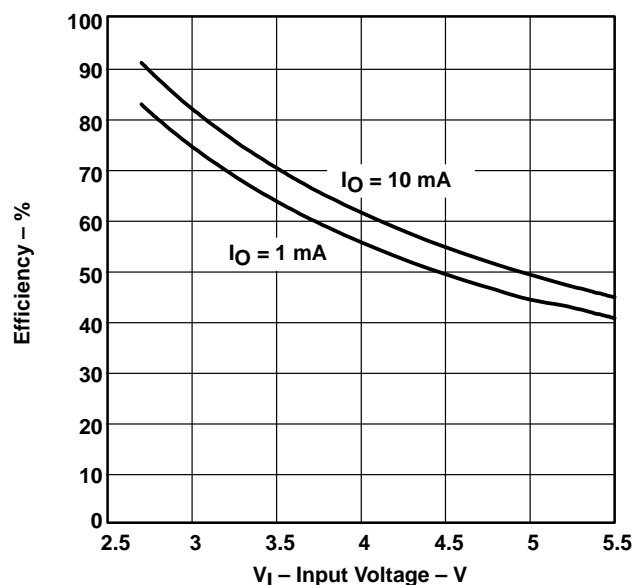

Figure 2

TPS60242  
EFFICIENCY  
VS  
INPUT VOLTAGE

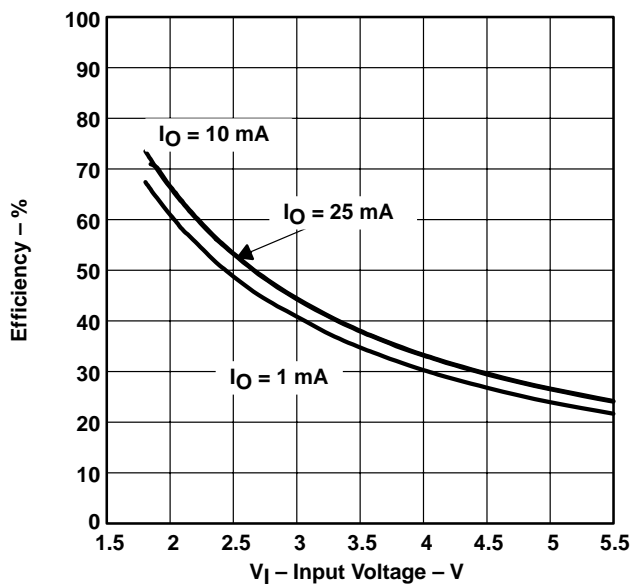

Figure 3

TPS60243  
EFFICIENCY  
VS  
INPUT VOLTAGE

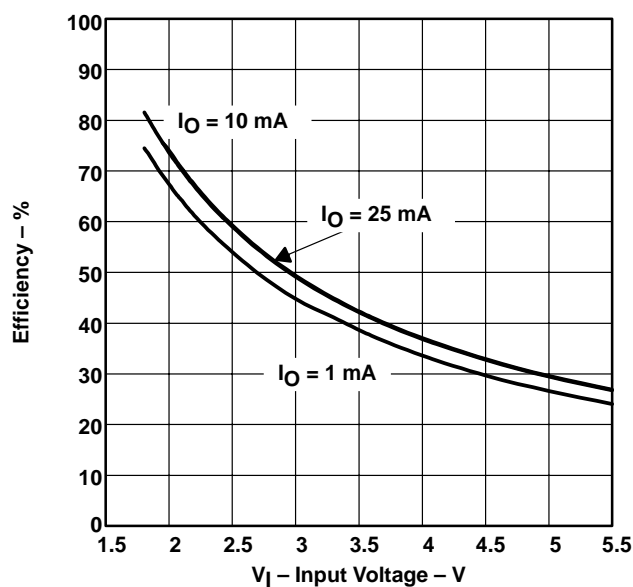

Figure 4

TYPICAL CHARACTERISTICS

TPS60240  
 EFFICIENCY  
 VS  
 OUTPUT CURRENT

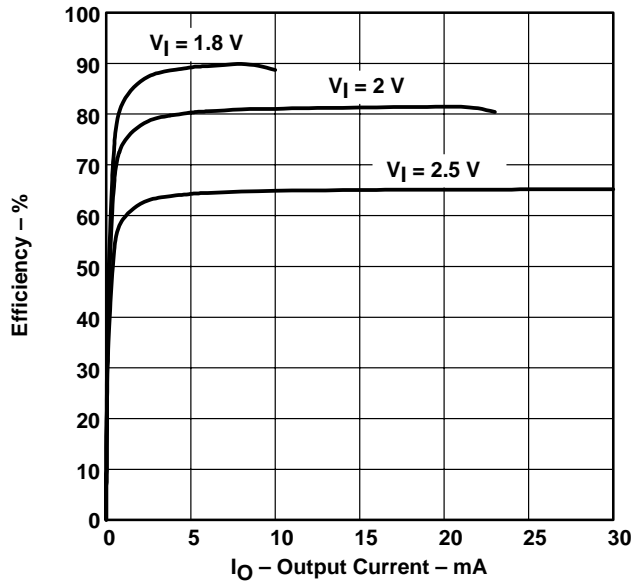

Figure 5

TPS60241  
 EFFICIENCY  
 VS  
 OUTPUT CURRENT

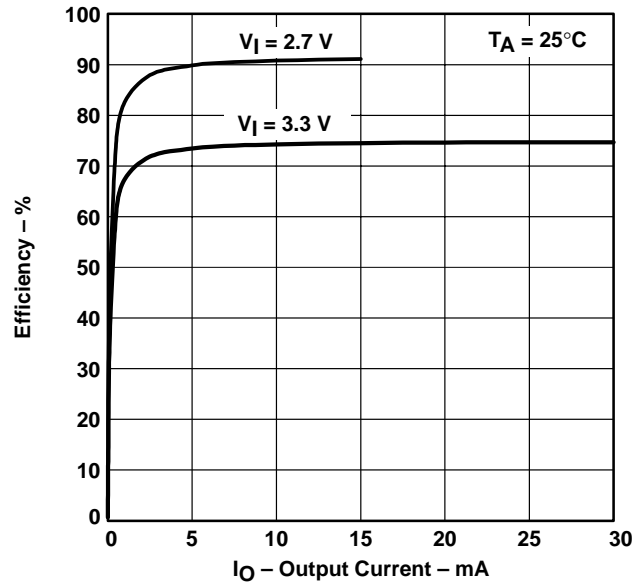

Figure 6

TPS60242  
 EFFICIENCY  
 VS  
 OUTPUT CURRENT

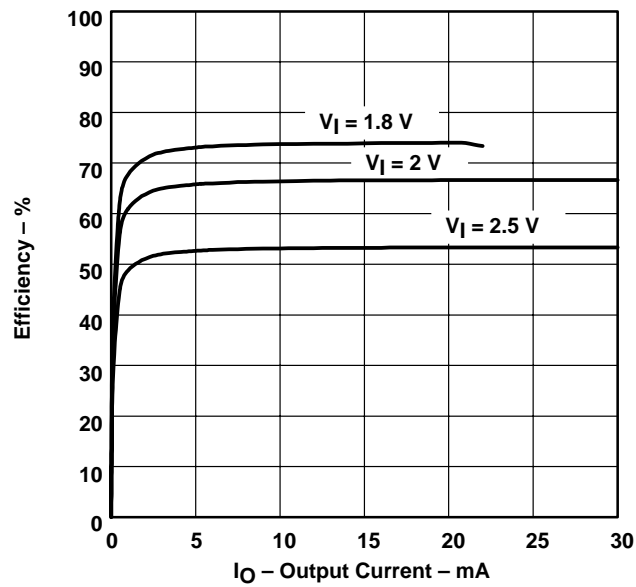

Figure 7

TPS60243  
 EFFICIENCY  
 VS  
 OUTPUT CURRENT

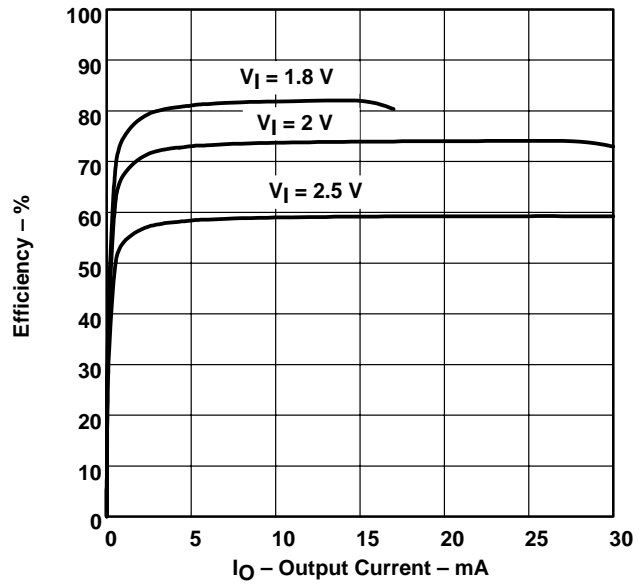

Figure 8



TYPICAL CHARACTERISTICS

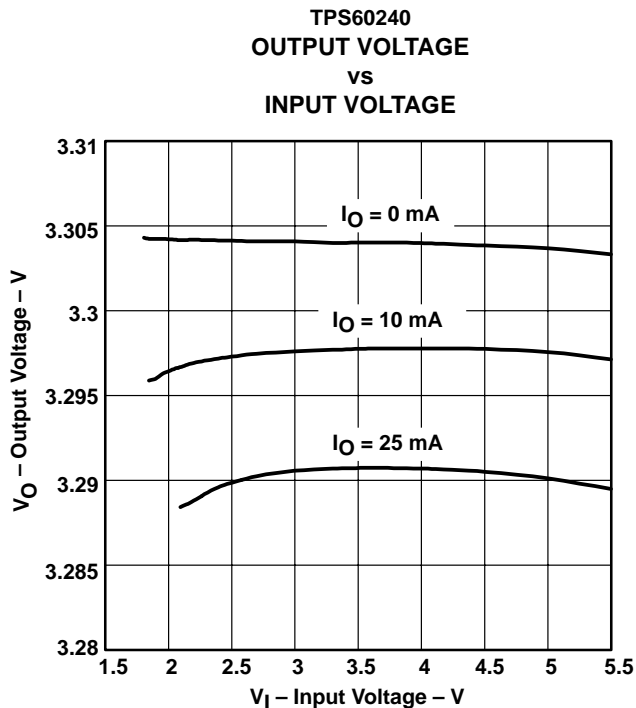

Figure 9

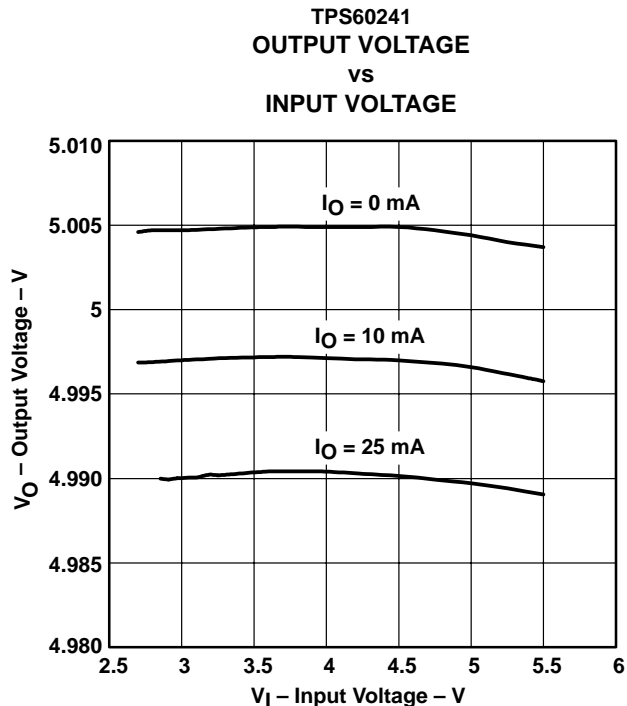

Figure 10

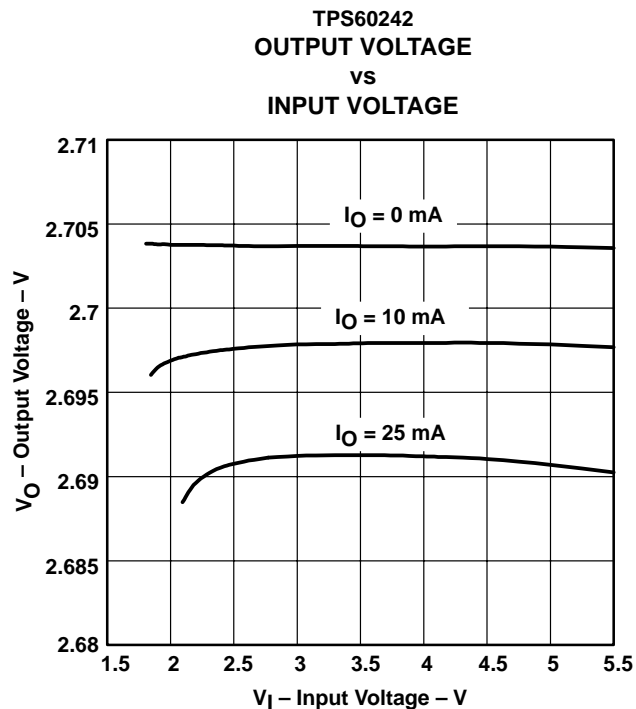

Figure 11

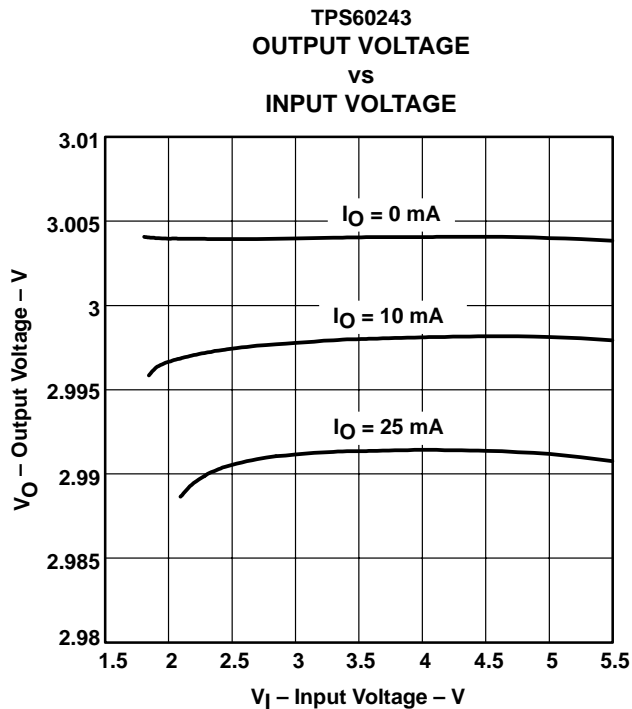

Figure 12

TYPICAL CHARACTERISTICS

TPS60240  
 OUTPUT VOLTAGE  
 VS  
 OUTPUT CURRENT

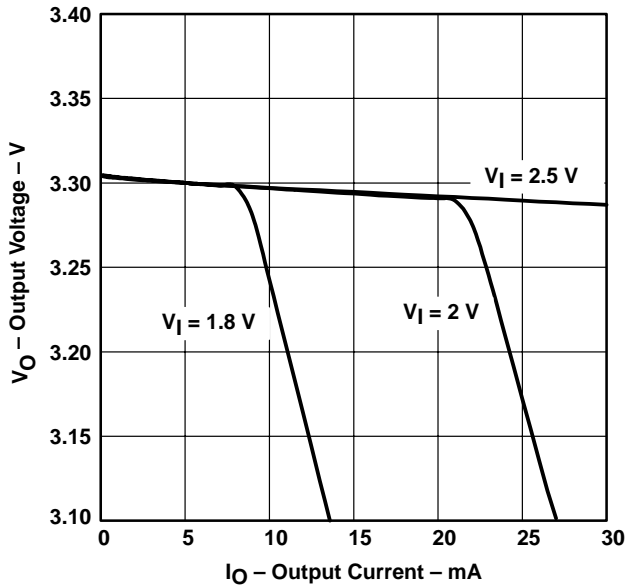

Figure 13

TPS60241  
 OUTPUT VOLTAGE  
 VS  
 OUTPUT CURRENT

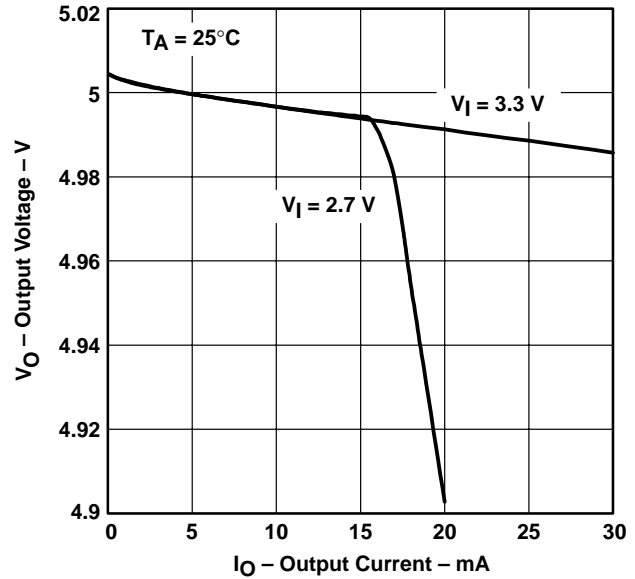

Figure 14

TPS60242  
 OUTPUT VOLTAGE  
 VS  
 OUTPUT CURRENT

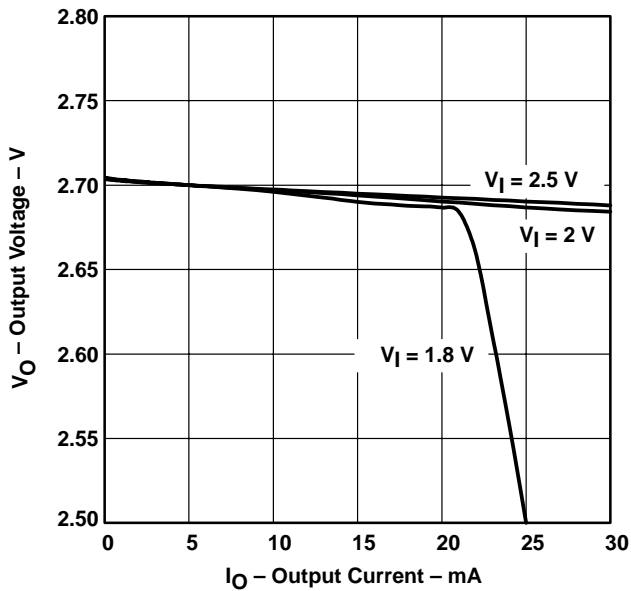

Figure 15

TPS60243  
 OUTPUT VOLTAGE  
 VS  
 OUTPUT CURRENT

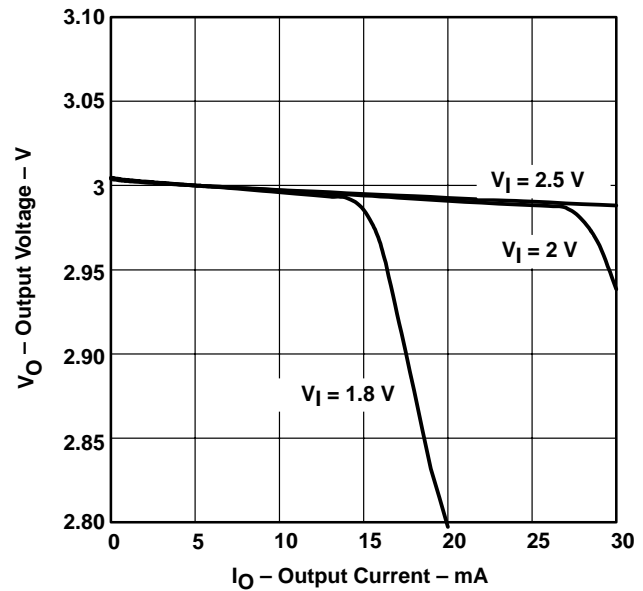

Figure 16

TYPICAL CHARACTERISTICS

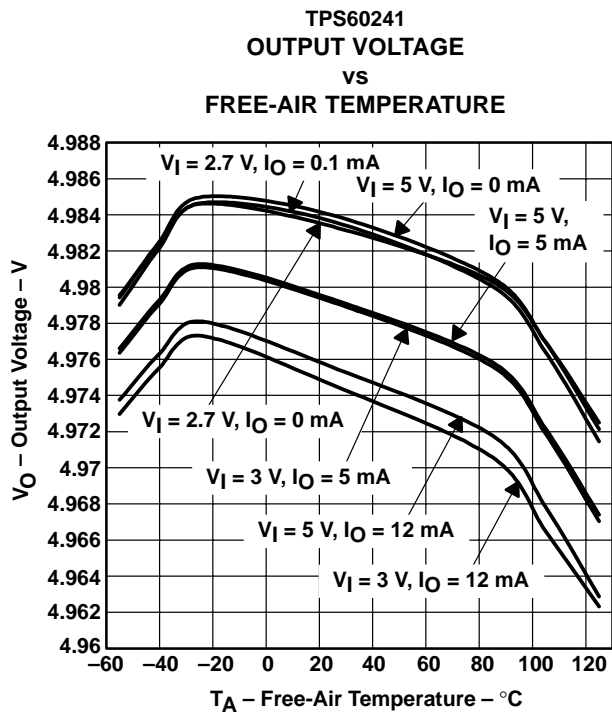

Figure 17

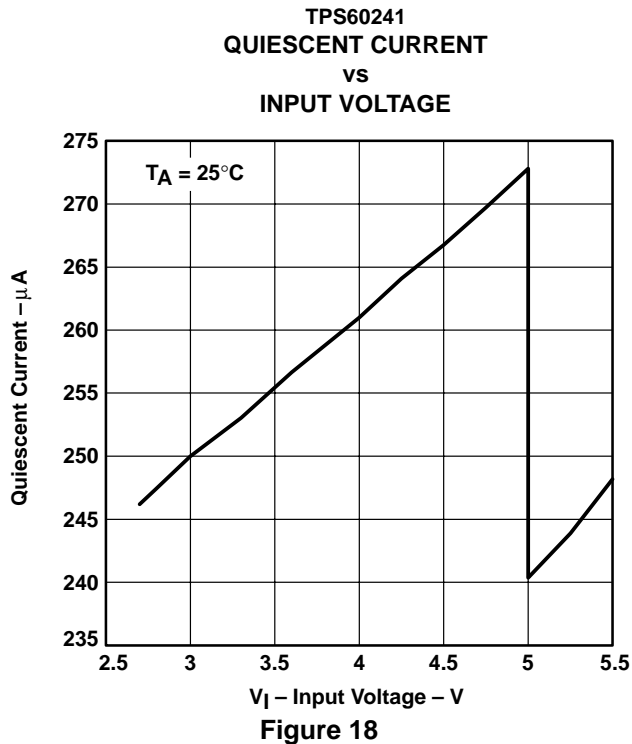

Figure 18

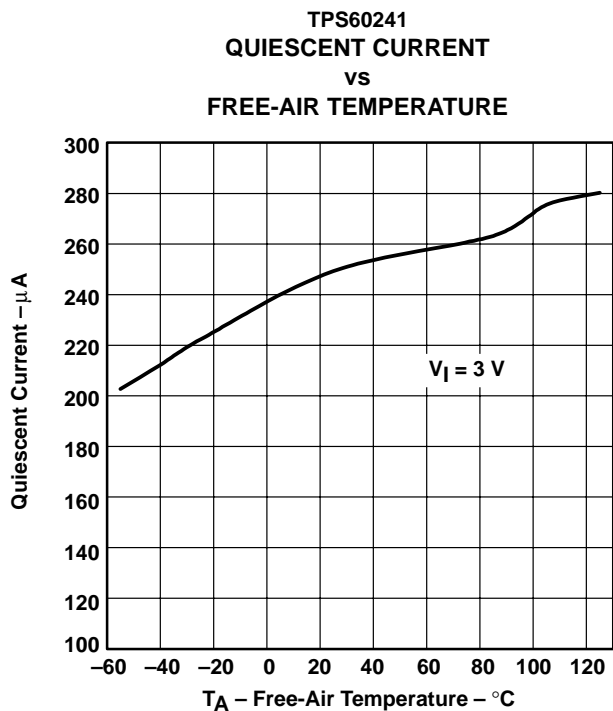

Figure 19

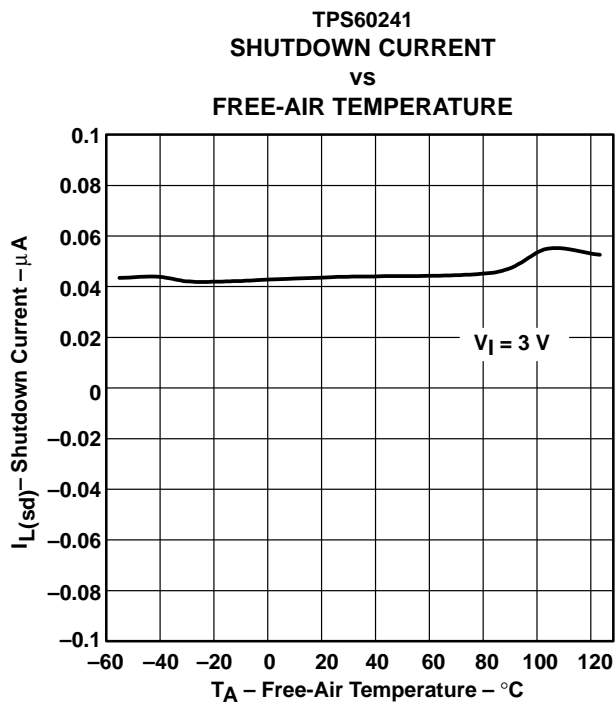
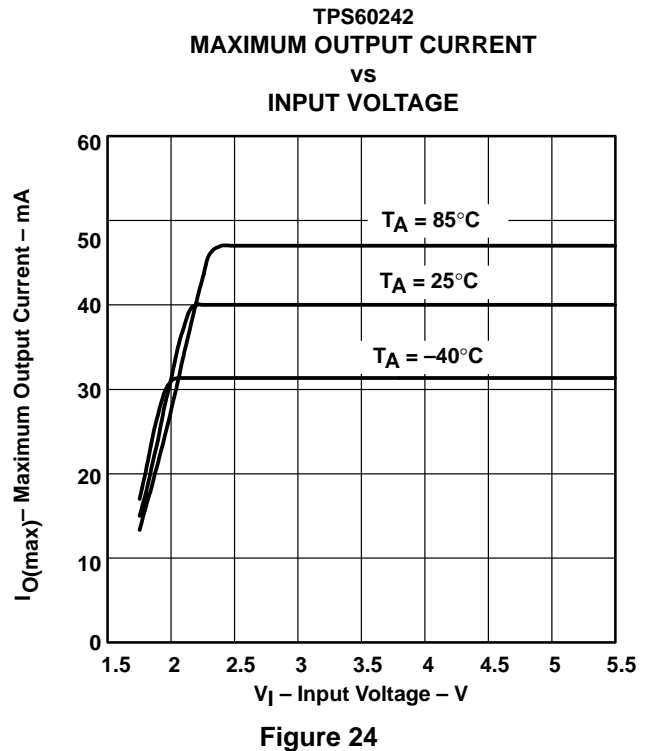
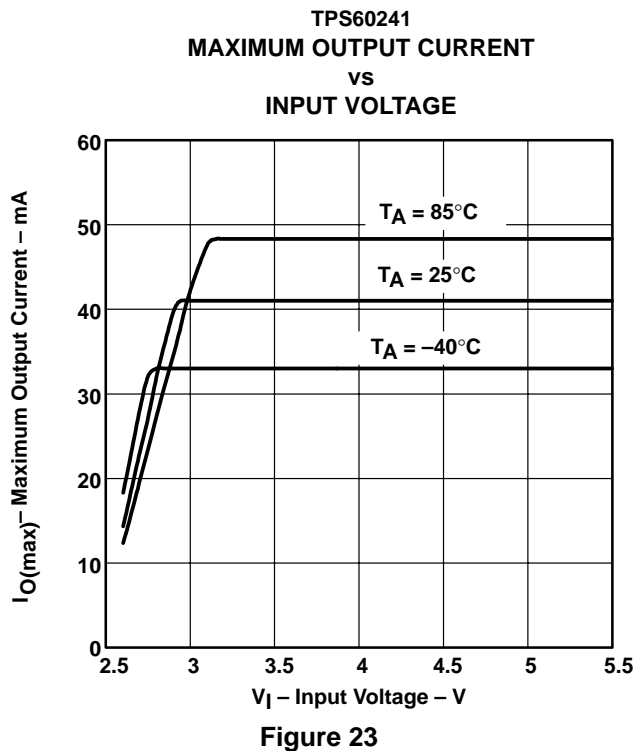
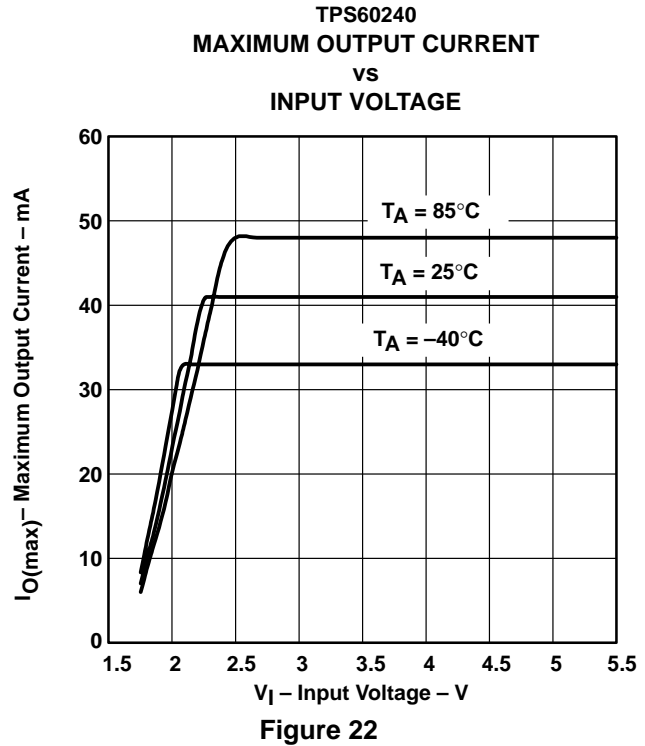
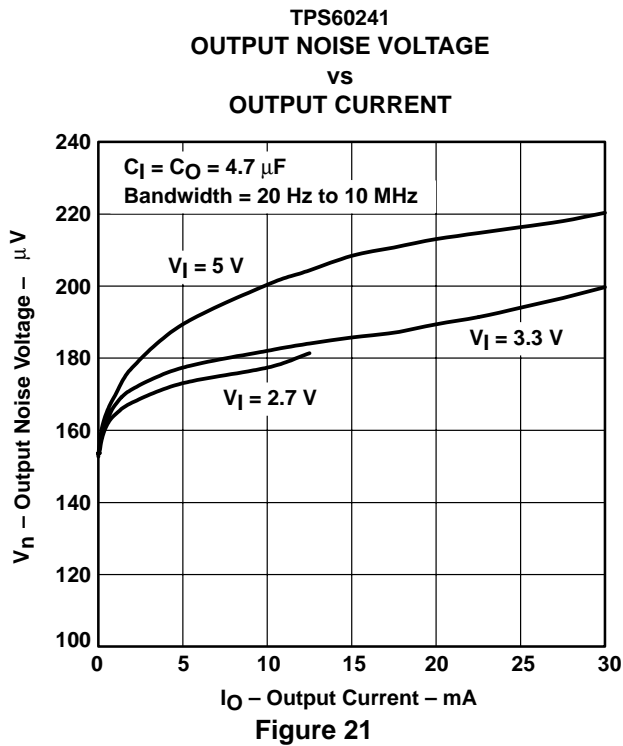

Figure 20

TYPICAL CHARACTERISTICS



TYPICAL CHARACTERISTICS

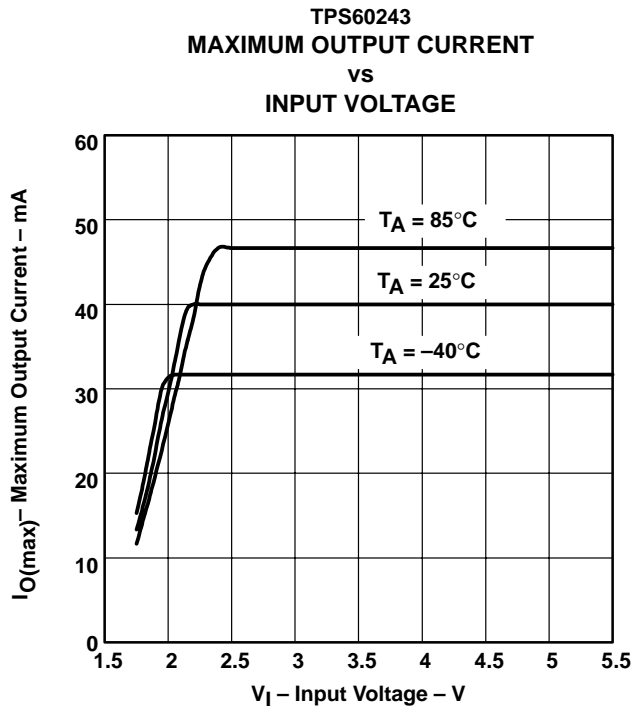

Figure 25

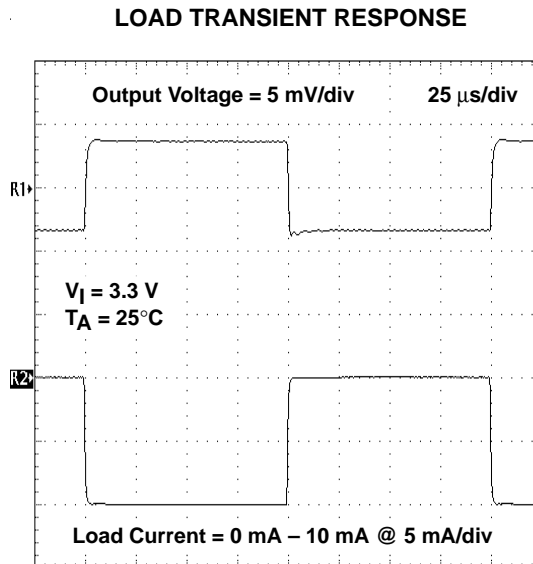

Figure 26

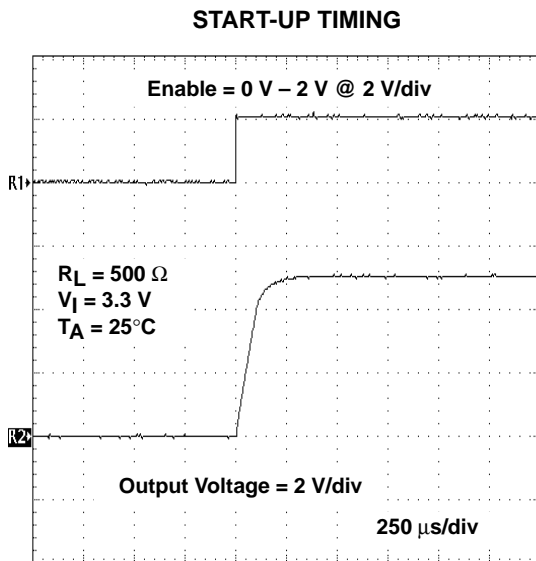

Figure 27

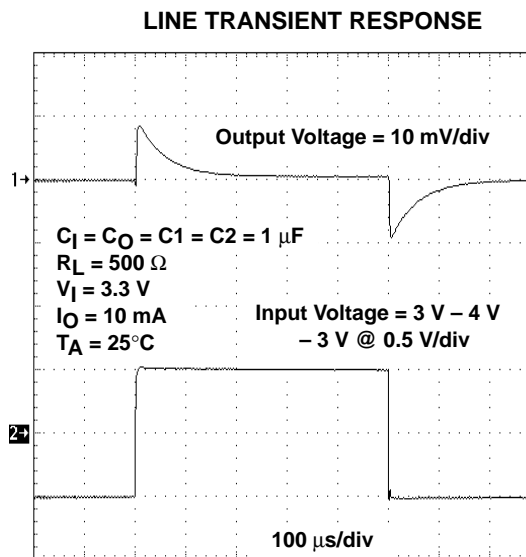
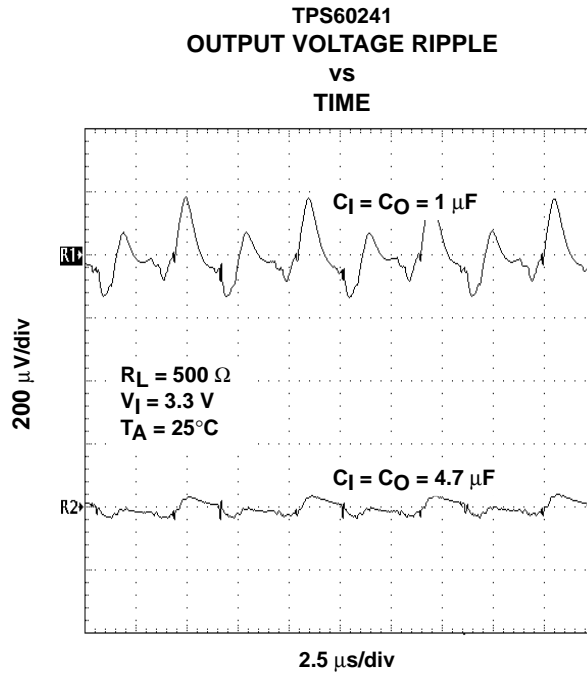
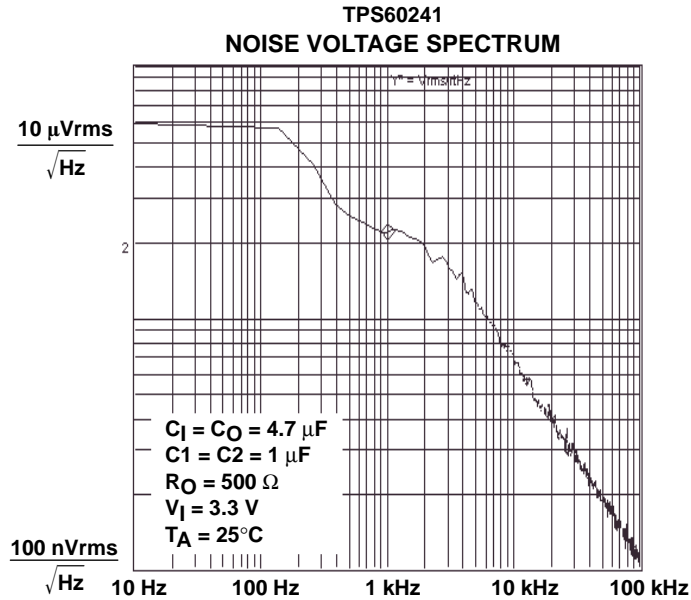

Figure 28

TYPICAL CHARACTERISTICS



NOTE: Scope triggered by voltage at flying capacitors, noise removed by averaging function and bandwidth limit 20 MHz.

APPLICATION INFORMATION

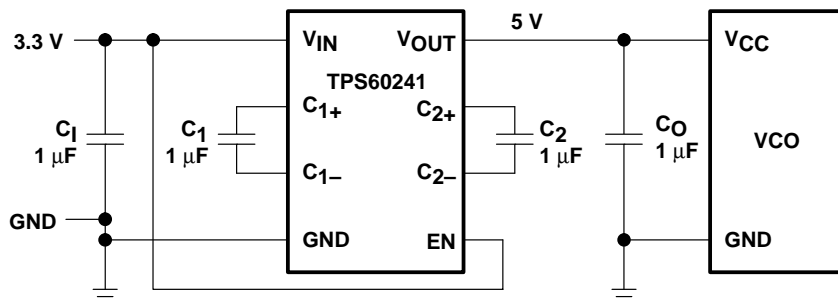

Figure 31. 5-V Low-Noise VCO Supply From 3.3-V Input

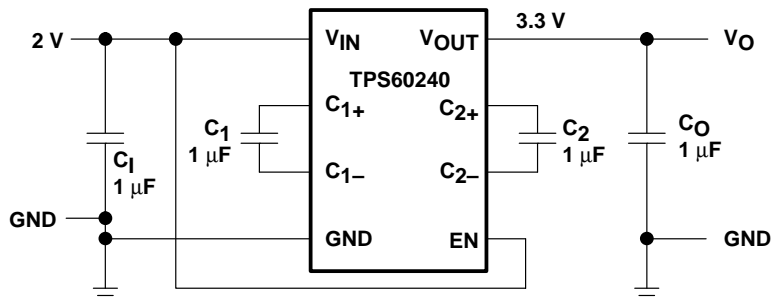

Figure 32. 2-V to 3.3-V Low-Noise Converter

output voltage ripple

The output voltage ripple depends on the capacitors used. Table 1 illustrates the dependence between output voltage ripple and capacitor selection.

Table 1. Output Voltage Ripple and Capacitor Selection

| C <sub>1</sub> | C <sub>0</sub> | C <sub>1</sub> | C <sub>2</sub> | OUTPUT VOLTAGE RIPPLE<br>[μVrms] |
|----------------|----------------|----------------|----------------|----------------------------------|
| 1 μF           | 1 μF           | 1 μF           | 1 μF           | 288                              |
| 2.2 μF         | 2.2 μF         | 1 μF           | 1 μF           | 212                              |
| 4.7 μF         | 4.7 μF         | 1 μF           | 1 μF           | 183                              |
| 4.7 μF         | 1 μF           | 1 μF           | 1 μF           | 272                              |
| 1 μF           | 4.7 μF         | 1 μF           | 1 μF           | 185                              |

NOTE: V<sub>I</sub> = 3.3 V, V<sub>O</sub> = 5 V, R<sub>L</sub> = 500 Ω, T<sub>A</sub> = 25°C

**APPLICATION INFORMATION**

**components**

For the best output ripple performance, low-ESR ceramic capacitors are recommended (see Table 2).

**Table 2. Recommended Capacitors**

| PART                            | MANUFACTURER | PART NUMBER     | VALUE       | TOLERANCE | DIELECTRIC MATERIAL | PACKAGE | RATED VOLTAGE |
|---------------------------------|--------------|-----------------|-------------|-----------|---------------------|---------|---------------|
| C <sub>I</sub>                  | Taiyo Yuden  | LMK212BJ105KG-T | 1 $\mu$ F   | 10%       | X7R                 | 0805    | 10            |
|                                 | TDK          | C2012X5R0J475K  | 4.7 $\mu$ F | 10%       | X5R                 | 0805    | 6.3           |
| C <sub>O</sub>                  | Taiyo Yuden  | LMK212BJ105KG-T | 1 $\mu$ F   | 10%       | X7R                 | 0805    | 10            |
|                                 | TDK          | C2012X5R0J475K  | 4.7 $\mu$ F | 10%       | X5R                 | 0805    | 6.3           |
| C <sub>1</sub> , C <sub>2</sub> | Taiyo Yuden  | LMK212BJ105KG-T | 1 $\mu$ F   | 10%       | X7R                 | 0805    | 10            |
| C <sub>F</sub>                  | Taiyo Yuden  | LMK212BJ105KG-T | 1 $\mu$ F   | 10%       | X7R                 | 0805    | 10            |

**layout consideration**

In order to get optimal noise behavior, keep the power lines to the capacitors and load as short as possible. Use of power planes is recommended.

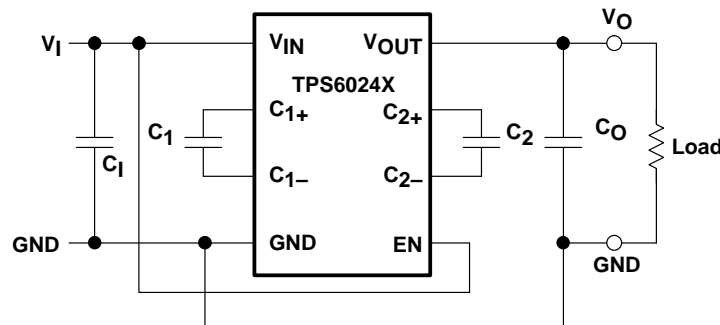

**Figure 33. Layout Diagram**



APPLICATION INFORMATION

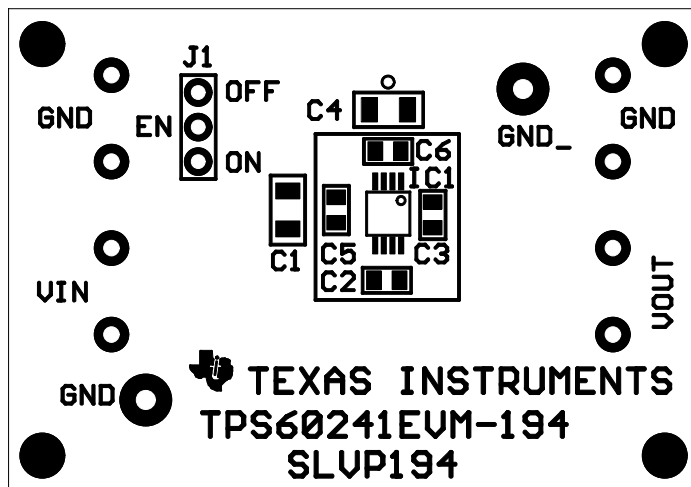

Figure 34. Top Silkscreen

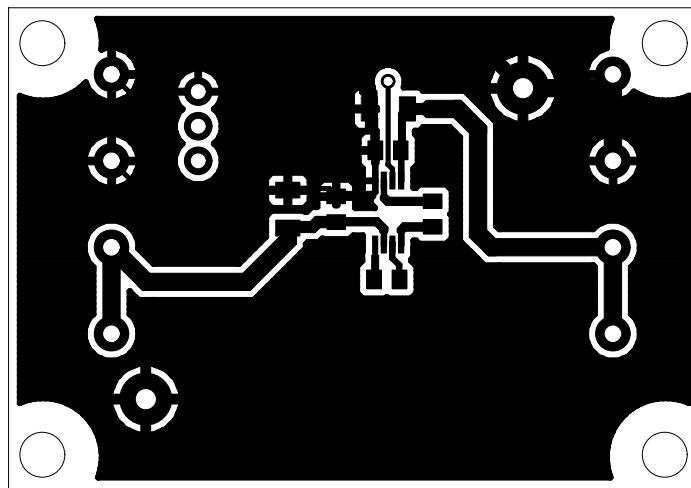

Figure 35. Top Layer

device family products

| PART NUMBER | DESCRIPTION   |
|-------------|---|
| REG710      | 30-mA switched cap dc/dc converter                          |
| REG711      | 50-mA switched cap dc/dc converter                          |
| TPS60110    | Regulated 5-V, 300-mA low-noise charge pump dc/dc converter |
| TPS60111    | Regulated 5-V, 150-mA low-noise charge pump dc/dc converter |

MECHANICAL DATA

DGK (R-PDSO-G8)

PLASTIC SMALL-OUTLINE PACKAGE

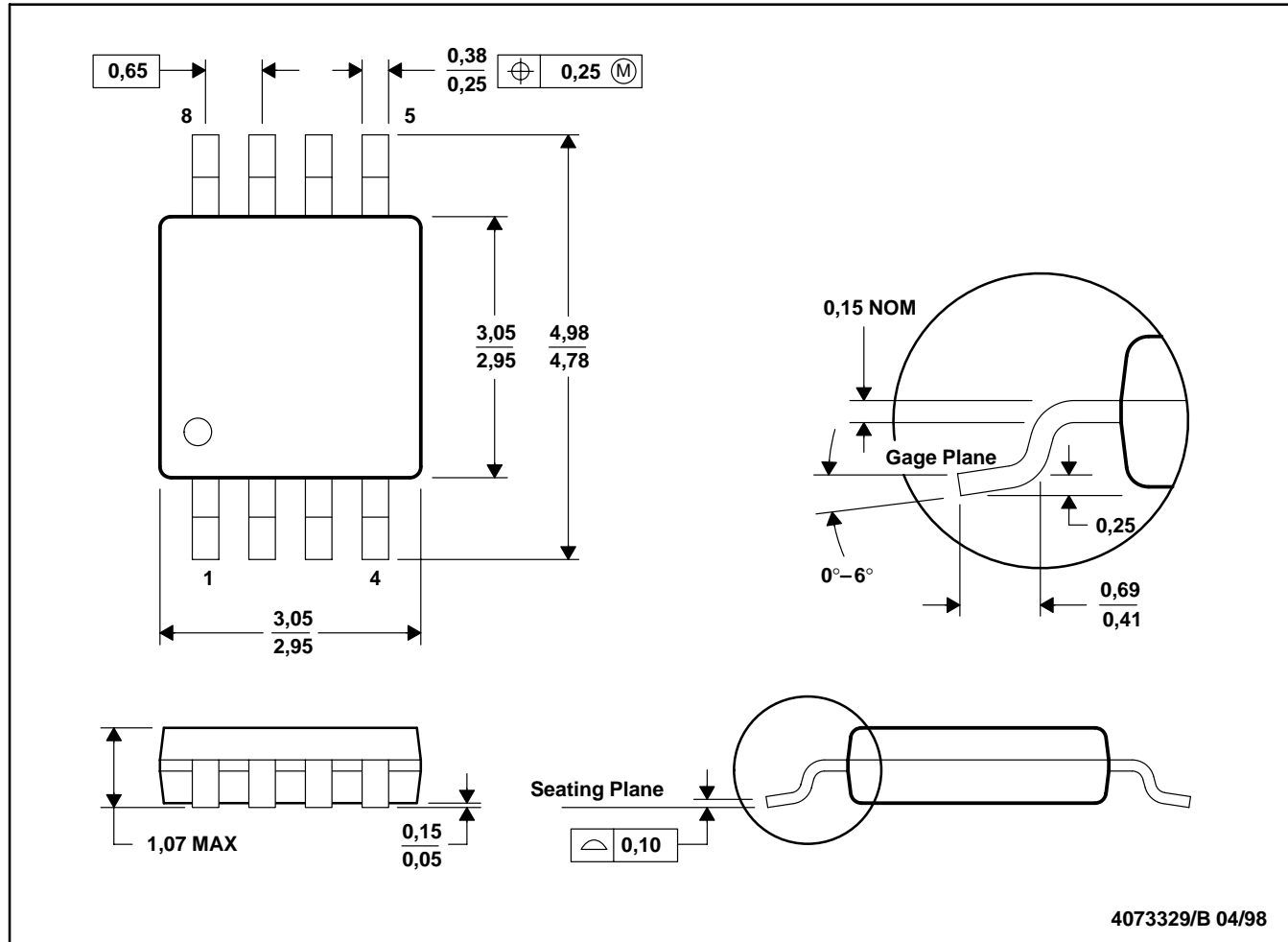

- NOTES: A. All linear dimensions are in millimeters.  
 B. This drawing is subject to change without notice.  
 C. Body dimensions do not include mold flash or protrusion.  
 D. Falls within JEDEC MO-187

**PACKAGING INFORMATION**

| Orderable Device | Status <sup>(1)</sup> | Package Type | Package Drawing | Pins | Package Qty | Eco Plan <sup>(2)</sup> | Lead/Ball Finish | MSL Peak Temp <sup>(3)</sup> |
|------------------|-----------------------|--------------|-----------------|------|-------------|-------------------------|------------------|------------------------------|
| TPS60240DGK      | OBSOLETE              | MSOP         | DGK             | 8    |             | TBD                     | Call TI          | Call TI                      |
| TPS60240DGKR     | ACTIVE                | MSOP         | DGK             | 8    | 2500        | Green (RoHS & no Sb/Br) | CU NIPDAU        | Level-2-260C-1 YEAR          |
| TPS60240DGKRG4   | ACTIVE                | MSOP         | DGK             | 8    | 2500        | Green (RoHS & no Sb/Br) | CU NIPDAU        | Level-2-260C-1 YEAR          |
| TPS60240DGKT     | ACTIVE                | MSOP         | DGK             | 8    | 250         | Green (RoHS & no Sb/Br) | CU NIPDAU        | Level-2-260C-1 YEAR          |
| TPS60240DGKTG4   | ACTIVE                | MSOP         | DGK             | 8    | 250         | Green (RoHS & no Sb/Br) | CU NIPDAU        | Level-2-260C-1 YEAR          |
| TPS60241DGKR     | ACTIVE                | MSOP         | DGK             | 8    | 2500        | Green (RoHS & no Sb/Br) | CU NIPDAU        | Level-2-260C-1 YEAR          |
| TPS60241DGKRG4   | ACTIVE                | MSOP         | DGK             | 8    | 2500        | Green (RoHS & no Sb/Br) | CU NIPDAU        | Level-2-260C-1 YEAR          |
| TPS60241DGKT     | ACTIVE                | MSOP         | DGK             | 8    | 250         | Green (RoHS & no Sb/Br) | CU NIPDAU        | Level-2-260C-1 YEAR          |
| TPS60241DGKTG4   | ACTIVE                | MSOP         | DGK             | 8    | 250         | Green (RoHS & no Sb/Br) | CU NIPDAU        | Level-2-260C-1 YEAR          |
| TPS60242DGK      | OBSOLETE              | MSOP         | DGK             | 8    |             | TBD                     | Call TI          | Call TI                      |
| TPS60242DGKR     | ACTIVE                | MSOP         | DGK             | 8    | 2500        | Green (RoHS & no Sb/Br) | CU NIPDAU        | Level-2-260C-1 YEAR          |
| TPS60242DGKRG4   | ACTIVE                | MSOP         | DGK             | 8    | 2500        | Green (RoHS & no Sb/Br) | CU NIPDAU        | Level-2-260C-1 YEAR          |
| TPS60242DGKT     | ACTIVE                | MSOP         | DGK             | 8    | 250         | Green (RoHS & no Sb/Br) | CU NIPDAU        | Level-2-260C-1 YEAR          |
| TPS60242DGKTG4   | ACTIVE                | MSOP         | DGK             | 8    | 250         | Green (RoHS & no Sb/Br) | CU NIPDAU        | Level-2-260C-1 YEAR          |
| TPS60243DGK      | OBSOLETE              | MSOP         | DGK             | 8    |             | TBD                     | Call TI          | Call TI                      |
| TPS60243DGKR     | ACTIVE                | MSOP         | DGK             | 8    | 2500        | Green (RoHS & no Sb/Br) | CU NIPDAU        | Level-2-260C-1 YEAR          |
| TPS60243DGKRG4   | ACTIVE                | MSOP         | DGK             | 8    | 2500        | Green (RoHS & no Sb/Br) | CU NIPDAU        | Level-2-260C-1 YEAR          |
| TPS60243DGKT     | ACTIVE                | MSOP         | DGK             | 8    | 250         | Green (RoHS & no Sb/Br) | CU NIPDAU        | Level-2-260C-1 YEAR          |
| TPS60243DGKTG4   | ACTIVE                | MSOP         | DGK             | 8    | 250         | Green (RoHS & no Sb/Br) | CU NIPDAU        | Level-2-260C-1 YEAR          |

<sup>(1)</sup> The marketing status values are defined as follows:

**ACTIVE:** Product device recommended for new designs.

**LIFEBUY:** TI has announced that the device will be discontinued, and a lifetime-buy period is in effect.

**NRND:** Not recommended for new designs. Device is in production to support existing customers, but TI does not recommend using this part in a new design.

**PREVIEW:** Device has been announced but is not in production. Samples may or may not be available.

**OBSOLETE:** TI has discontinued the production of the device.

<sup>(2)</sup> Eco Plan - The planned eco-friendly classification: Pb-Free (RoHS), Pb-Free (RoHS Exempt), or Green (RoHS & no Sb/Br) - please check <http://www.ti.com/productcontent> for the latest availability information and additional product content details.

**TBD:** The Pb-Free/Green conversion plan has not been defined.

**Pb-Free (RoHS):** TI's terms "Lead-Free" or "Pb-Free" mean semiconductor products that are compatible with the current RoHS requirements for all 6 substances, including the requirement that lead not exceed 0.1% by weight in homogeneous materials. Where designed to be soldered at high temperatures, TI Pb-Free products are suitable for use in specified lead-free processes.

**Pb-Free (RoHS Exempt):** This component has a RoHS exemption for either 1) lead-based flip-chip solder bumps used between the die and package, or 2) lead-based die adhesive used between the die and leadframe. The component is otherwise considered Pb-Free (RoHS

compatible) as defined above.

**Green (RoHS & no Sb/Br):** TI defines "Green" to mean Pb-Free (RoHS compatible), and free of Bromine (Br) and Antimony (Sb) based flame retardants (Br or Sb do not exceed 0.1% by weight in homogeneous material)

(3) MSL, Peak Temp. -- The Moisture Sensitivity Level rating according to the JEDEC industry standard classifications, and peak solder temperature.

**Important Information and Disclaimer:**The information provided on this page represents TI's knowledge and belief as of the date that it is provided. TI bases its knowledge and belief on information provided by third parties, and makes no representation or warranty as to the accuracy of such information. Efforts are underway to better integrate information from third parties. TI has taken and continues to take reasonable steps to provide representative and accurate information but may not have conducted destructive testing or chemical analysis on incoming materials and chemicals. TI and TI suppliers consider certain information to be proprietary, and thus CAS numbers and other limited information may not be available for release.

In no event shall TI's liability arising out of such information exceed the total purchase price of the TI part(s) at issue in this document sold by TI to Customer on an annual basis.

**TAPE AND REEL INFORMATION**



**QUADRANT ASSIGNMENTS FOR PIN 1 ORIENTATION IN TAPE**

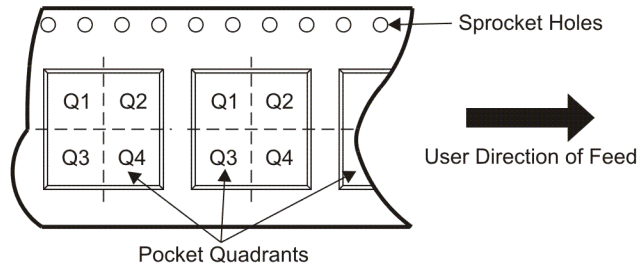

\*All dimensions are nominal

| Device       | Package Type | Package Drawing | Pins | SPQ  | Reel Diameter (mm) | Reel Width W1 (mm) | A0 (mm) | B0 (mm) | K0 (mm) | P1 (mm) | W (mm) | Pin1 Quadrant |
|--------------|--------------|-----------------|------|------|--------------------|--------------------|---------|---------|---------|---------|--------|---------------|
| TPS60240DGKR | MSOP         | DGK             | 8    | 2500 | 330.0              | 12.4               | 5.3     | 3.4     | 1.4     | 8.0     | 12.0   | Q1            |
| TPS60240DGKT | MSOP         | DGK             | 8    | 250  | 180.0              | 12.4               | 5.3     | 3.4     | 1.4     | 8.0     | 12.0   | Q1            |
| TPS60241DGKR | MSOP         | DGK             | 8    | 2500 | 330.0              | 12.4               | 5.3     | 3.4     | 1.4     | 8.0     | 12.0   | Q1            |
| TPS60241DGKT | MSOP         | DGK             | 8    | 250  | 180.0              | 12.4               | 5.3     | 3.4     | 1.4     | 8.0     | 12.0   | Q1            |
| TPS60242DGKR | MSOP         | DGK             | 8    | 2500 | 330.0              | 12.4               | 5.3     | 3.4     | 1.4     | 8.0     | 12.0   | Q1            |
| TPS60242DGKT | MSOP         | DGK             | 8    | 250  | 180.0              | 12.4               | 5.3     | 3.4     | 1.4     | 8.0     | 12.0   | Q1            |
| TPS60243DGKR | MSOP         | DGK             | 8    | 2500 | 330.0              | 12.4               | 5.3     | 3.4     | 1.4     | 8.0     | 12.0   | Q1            |
| TPS60243DGKT | MSOP         | DGK             | 8    | 250  | 180.0              | 12.4               | 5.3     | 3.4     | 1.4     | 8.0     | 12.0   | Q1            |

**TAPE AND REEL BOX DIMENSIONS**



\*All dimensions are nominal

| Device       | Package Type | Package Drawing | Pins | SPQ  | Length (mm) | Width (mm) | Height (mm) |
|--------------|--------------|-----------------|------|------|-------------|------------|-------------|
| TPS60240DGKR | MSOP         | DGK             | 8    | 2500 | 346.0       | 346.0      | 29.0        |
| TPS60240DGKT | MSOP         | DGK             | 8    | 250  | 190.5       | 212.7      | 31.8        |
| TPS60241DGKR | MSOP         | DGK             | 8    | 2500 | 346.0       | 346.0      | 29.0        |
| TPS60241DGKT | MSOP         | DGK             | 8    | 250  | 190.5       | 212.7      | 31.8        |
| TPS60242DGKR | MSOP         | DGK             | 8    | 2500 | 346.0       | 346.0      | 29.0        |
| TPS60242DGKT | MSOP         | DGK             | 8    | 250  | 190.5       | 212.7      | 31.8        |
| TPS60243DGKR | MSOP         | DGK             | 8    | 2500 | 346.0       | 346.0      | 29.0        |
| TPS60243DGKT | MSOP         | DGK             | 8    | 250  | 190.5       | 212.7      | 31.8        |

**PACKAGING INFORMATION**

| Orderable Device | Status<br>(1) | Package Type | Package<br>Drawing | Pins | Package<br>Qty | Eco Plan<br>(2)            | Lead/Ball Finish<br>(6) | MSL Peak Temp<br>(3) | Op Temp (°C) | Device Marking<br>(4/5) | Samples                 |
|------------------|---------------|--------------|--------------------|------|----------------|----------------------------|-------------------------|----------------------|--------------|-------------------------|-------------------------|
| TPS60240DGK      | OBSOLETE      | VSSOP        | DGK                | 8    |                | TBD                        | Call TI                 | Call TI              |              |                         |                         |
| TPS60240DGKR     | ACTIVE        | VSSOP        | DGK                | 8    | 2500           | Green (RoHS<br>& no Sb/Br) | CU NIPDAUAG             | Level-2-260C-1 YEAR  | -40 to 85    | ATM                     | <a href="#">Samples</a> |
| TPS60240DGKT     | ACTIVE        | VSSOP        | DGK                | 8    | 250            | Green (RoHS<br>& no Sb/Br) | CU NIPDAUAG             | Level-2-260C-1 YEAR  | -40 to 85    | ATM                     | <a href="#">Samples</a> |
| TPS60240DGKTG4   | ACTIVE        | VSSOP        | DGK                | 8    | 250            | Green (RoHS<br>& no Sb/Br) | CU NIPDAUAG             | Level-2-260C-1 YEAR  | -40 to 85    | ATM                     | <a href="#">Samples</a> |
| TPS60241DGKR     | ACTIVE        | VSSOP        | DGK                | 8    | 2500           | Green (RoHS<br>& no Sb/Br) | CU NIPDAUAG             | Level-2-260C-1 YEAR  | -40 to 85    | AUB                     | <a href="#">Samples</a> |
| TPS60241DGKRG4   | ACTIVE        | VSSOP        | DGK                | 8    | 2500           | Green (RoHS<br>& no Sb/Br) | CU NIPDAUAG             | Level-2-260C-1 YEAR  | -40 to 85    | AUB                     | <a href="#">Samples</a> |
| TPS60241DGKT     | ACTIVE        | VSSOP        | DGK                | 8    | 250            | Green (RoHS<br>& no Sb/Br) | CU NIPDAUAG             | Level-2-260C-1 YEAR  | -40 to 85    | AUB                     | <a href="#">Samples</a> |
| TPS60241DGKTG4   | ACTIVE        | VSSOP        | DGK                | 8    | 250            | Green (RoHS<br>& no Sb/Br) | CU NIPDAUAG             | Level-2-260C-1 YEAR  | -40 to 85    | AUB                     | <a href="#">Samples</a> |
| TPS60242DGK      | OBSOLETE      | VSSOP        | DGK                | 8    |                | TBD                        | Call TI                 | Call TI              |              |                         |                         |
| TPS60242DGKT     | ACTIVE        | VSSOP        | DGK                | 8    | 250            | Green (RoHS<br>& no Sb/Br) | CU NIPDAUAG             | Level-2-260C-1 YEAR  | -40 to 85    | AYF                     | <a href="#">Samples</a> |
| TPS60243DGK      | OBSOLETE      | VSSOP        | DGK                | 8    |                | TBD                        | Call TI                 | Call TI              |              |                         |                         |
| TPS60243DGKR     | ACTIVE        | VSSOP        | DGK                | 8    | 2500           | Green (RoHS<br>& no Sb/Br) | CU NIPDAUAG             | Level-2-260C-1 YEAR  | -40 to 85    | AYG                     | <a href="#">Samples</a> |
| TPS60243DGKT     | ACTIVE        | VSSOP        | DGK                | 8    | 250            | Green (RoHS<br>& no Sb/Br) | CU NIPDAUAG             | Level-2-260C-1 YEAR  | -40 to 85    | AYG                     | <a href="#">Samples</a> |
| TPS60243DGKTG4   | ACTIVE        | VSSOP        | DGK                | 8    | 250            | Green (RoHS<br>& no Sb/Br) | CU NIPDAUAG             | Level-2-260C-1 YEAR  | -40 to 85    | AYG                     | <a href="#">Samples</a> |

(1) The marketing status values are defined as follows:

**ACTIVE:** Product device recommended for new designs.

**LIFEBUY:** TI has announced that the device will be discontinued, and a lifetime-buy period is in effect.

**NRND:** Not recommended for new designs. Device is in production to support existing customers, but TI does not recommend using this part in a new design.

**PREVIEW:** Device has been announced but is not in production. Samples may or may not be available.

**OBSOLETE:** TI has discontinued the production of the device.

(2) Eco Plan - The planned eco-friendly classification: Pb-Free (RoHS), Pb-Free (RoHS Exempt), or Green (RoHS & no Sb/Br) - please check <http://www.ti.com/productcontent> for the latest availability information and additional product content details.

**TBD:** The Pb-Free/Green conversion plan has not been defined.

**Pb-Free (RoHS):** TI's terms "Lead-Free" or "Pb-Free" mean semiconductor products that are compatible with the current RoHS requirements for all 6 substances, including the requirement that lead not exceed 0.1% by weight in homogeneous materials. Where designed to be soldered at high temperatures, TI Pb-Free products are suitable for use in specified lead-free processes.

**Pb-Free (RoHS Exempt):** This component has a RoHS exemption for either 1) lead-based flip-chip solder bumps used between the die and package, or 2) lead-based die adhesive used between the die and leadframe. The component is otherwise considered Pb-Free (RoHS compatible) as defined above.

**Green (RoHS & no Sb/Br):** TI defines "Green" to mean Pb-Free (RoHS compatible), and free of Bromine (Br) and Antimony (Sb) based flame retardants (Br or Sb do not exceed 0.1% by weight in homogeneous material)

(3) MSL, Peak Temp. - The Moisture Sensitivity Level rating according to the JEDEC industry standard classifications, and peak solder temperature.

(4) There may be additional marking, which relates to the logo, the lot trace code information, or the environmental category on the device.

(5) Multiple Device Markings will be inside parentheses. Only one Device Marking contained in parentheses and separated by a "~" will appear on a device. If a line is indented then it is a continuation of the previous line and the two combined represent the entire Device Marking for that device.

(6) Lead/Ball Finish - Orderable Devices may have multiple material finish options. Finish options are separated by a vertical ruled line. Lead/Ball Finish values may wrap to two lines if the finish value exceeds the maximum column width.

**Important Information and Disclaimer:** The information provided on this page represents TI's knowledge and belief as of the date that it is provided. TI bases its knowledge and belief on information provided by third parties, and makes no representation or warranty as to the accuracy of such information. Efforts are underway to better integrate information from third parties. TI has taken and continues to take reasonable steps to provide representative and accurate information but may not have conducted destructive testing or chemical analysis on incoming materials and chemicals. TI and TI suppliers consider certain information to be proprietary, and thus CAS numbers and other limited information may not be available for release.

In no event shall TI's liability arising out of such information exceed the total purchase price of the TI part(s) at issue in this document sold by TI to Customer on an annual basis.



**TAPE AND REEL INFORMATION**

**QUADRANT ASSIGNMENTS FOR PIN 1 ORIENTATION IN TAPE**

\*All dimensions are nominal

| Device       | Package Type | Package Drawing | Pins | SPQ  | Reel Diameter (mm) | Reel Width W1 (mm) | A0 (mm) | B0 (mm) | K0 (mm) | P1 (mm) | W (mm) | Pin1 Quadrant |
|--------------|--------------|-----------------|------|------|--------------------|--------------------|---------|---------|---------|---------|--------|---------------|
| TPS60240DGKR | VSSOP        | DGK             | 8    | 2500 | 330.0              | 12.4               | 5.3     | 3.4     | 1.4     | 8.0     | 12.0   | Q1            |
| TPS60240DGKT | VSSOP        | DGK             | 8    | 250  | 180.0              | 12.4               | 5.3     | 3.4     | 1.4     | 8.0     | 12.0   | Q1            |
| TPS60241DGKR | VSSOP        | DGK             | 8    | 2500 | 330.0              | 12.4               | 5.3     | 3.4     | 1.4     | 8.0     | 12.0   | Q1            |
| TPS60241DGKT | VSSOP        | DGK             | 8    | 250  | 180.0              | 12.4               | 5.3     | 3.4     | 1.4     | 8.0     | 12.0   | Q1            |
| TPS60242DGKT | VSSOP        | DGK             | 8    | 250  | 180.0              | 12.4               | 5.3     | 3.4     | 1.4     | 8.0     | 12.0   | Q1            |
| TPS60243DGKR | VSSOP        | DGK             | 8    | 2500 | 330.0              | 12.4               | 5.3     | 3.4     | 1.4     | 8.0     | 12.0   | Q1            |
| TPS60243DGKT | VSSOP        | DGK             | 8    | 250  | 180.0              | 12.4               | 5.3     | 3.4     | 1.4     | 8.0     | 12.0   | Q1            |

**TAPE AND REEL BOX DIMENSIONS**

\*All dimensions are nominal

| Device       | Package Type | Package Drawing | Pins | SPQ  | Length (mm) | Width (mm) | Height (mm) |
|--------------|--------------|-----------------|------|------|-------------|------------|-------------|
| TPS60240DGKR | VSSOP        | DGK             | 8    | 2500 | 367.0       | 367.0      | 35.0        |
| TPS60240DGKT | VSSOP        | DGK             | 8    | 250  | 210.0       | 185.0      | 35.0        |
| TPS60241DGKR | VSSOP        | DGK             | 8    | 2500 | 367.0       | 367.0      | 35.0        |
| TPS60241DGKT | VSSOP        | DGK             | 8    | 250  | 210.0       | 185.0      | 35.0        |
| TPS60242DGKT | VSSOP        | DGK             | 8    | 250  | 210.0       | 185.0      | 35.0        |
| TPS60243DGKR | VSSOP        | DGK             | 8    | 2500 | 367.0       | 367.0      | 35.0        |
| TPS60243DGKT | VSSOP        | DGK             | 8    | 250  | 210.0       | 185.0      | 35.0        |

## IMPORTANT NOTICE

Texas Instruments Incorporated and its subsidiaries (TI) reserve the right to make corrections, enhancements, improvements and other changes to its semiconductor products and services per JESD46, latest issue, and to discontinue any product or service per JESD48, latest issue. Buyers should obtain the latest relevant information before placing orders and should verify that such information is current and complete. All semiconductor products (also referred to herein as "components") are sold subject to TI's terms and conditions of sale supplied at the time of order acknowledgment.

TI warrants performance of its components to the specifications applicable at the time of sale, in accordance with the warranty in TI's terms and conditions of sale of semiconductor products. Testing and other quality control techniques are used to the extent TI deems necessary to support this warranty. Except where mandated by applicable law, testing of all parameters of each component is not necessarily performed.

TI assumes no liability for applications assistance or the design of Buyers' products. Buyers are responsible for their products and applications using TI components. To minimize the risks associated with Buyers' products and applications, Buyers should provide adequate design and operating safeguards.

TI does not warrant or represent that any license, either express or implied, is granted under any patent right, copyright, mask work right, or other intellectual property right relating to any combination, machine, or process in which TI components or services are used. Information published by TI regarding third-party products or services does not constitute a license to use such products or services or a warranty or endorsement thereof. Use of such information may require a license from a third party under the patents or other intellectual property of the third party, or a license from TI under the patents or other intellectual property of TI.

Reproduction of significant portions of TI information in TI data books or data sheets is permissible only if reproduction is without alteration and is accompanied by all associated warranties, conditions, limitations, and notices. TI is not responsible or liable for such altered documentation. Information of third parties may be subject to additional restrictions.

Resale of TI components or services with statements different from or beyond the parameters stated by TI for that component or service voids all express and any implied warranties for the associated TI component or service and is an unfair and deceptive business practice. TI is not responsible or liable for any such statements.

Buyer acknowledges and agrees that it is solely responsible for compliance with all legal, regulatory and safety-related requirements concerning its products, and any use of TI components in its applications, notwithstanding any applications-related information or support that may be provided by TI. Buyer represents and agrees that it has all the necessary expertise to create and implement safeguards which anticipate dangerous consequences of failures, monitor failures and their consequences, lessen the likelihood of failures that might cause harm and take appropriate remedial actions. Buyer will fully indemnify TI and its representatives against any damages arising out of the use of any TI components in safety-critical applications.

In some cases, TI components may be promoted specifically to facilitate safety-related applications. With such components, TI's goal is to help enable customers to design and create their own end-product solutions that meet applicable functional safety standards and requirements. Nonetheless, such components are subject to these terms.

No TI components are authorized for use in FDA Class III (or similar life-critical medical equipment) unless authorized officers of the parties have executed a special agreement specifically governing such use.

Only those TI components which TI has specifically designated as military grade or "enhanced plastic" are designed and intended for use in military/aerospace applications or environments. Buyer acknowledges and agrees that any military or aerospace use of TI components which have **not** been so designated is solely at the Buyer's risk, and that Buyer is solely responsible for compliance with all legal and regulatory requirements in connection with such use.

TI has specifically designated certain components as meeting ISO/TS16949 requirements, mainly for automotive use. In any case of use of non-designated products, TI will not be responsible for any failure to meet ISO/TS16949.

### Products

|                              |  |
|------------------------------|--|
| Audio                        | <a href="http://www.ti.com/audio">www.ti.com/audio</a>                               |
| Amplifiers                   | <a href="http://amplifier.ti.com">amplifier.ti.com</a>                               |
| Data Converters              | <a href="http://dataconverter.ti.com">dataconverter.ti.com</a>                       |
| DLP® Products                | <a href="http://www.dlp.com">www.dlp.com</a>   |
| DSP                          | <a href="http://dsp.ti.com">dsp.ti.com</a>   |
| Clocks and Timers            | <a href="http://www.ti.com/clocks">www.ti.com/clocks</a>                             |
| Interface                    | <a href="http://interface.ti.com">interface.ti.com</a>                               |
| Logic                        | <a href="http://logic.ti.com">logic.ti.com</a>                                       |
| Power Mgmt                   | <a href="http://power.ti.com">power.ti.com</a>                                       |
| Microcontrollers             | <a href="http://microcontroller.ti.com">microcontroller.ti.com</a>                   |
| RFID                         | <a href="http://www.ti-rfid.com">www.ti-rfid.com</a>                                 |
| OMAP Applications Processors | <a href="http://www.ti.com/omap">www.ti.com/omap</a>                                 |
| Wireless Connectivity        | <a href="http://www.ti.com/wirelessconnectivity">www.ti.com/wirelessconnectivity</a> |

### Applications

|                               |  |
|-------------------------------|--|
| Automotive and Transportation | <a href="http://www.ti.com/automotive">www.ti.com/automotive</a>                         |
| Communications and Telecom    | <a href="http://www.ti.com/communications">www.ti.com/communications</a>                 |
| Computers and Peripherals     | <a href="http://www.ti.com/computers">www.ti.com/computers</a>                           |
| Consumer Electronics          | <a href="http://www.ti.com/consumer-apps">www.ti.com/consumer-apps</a>                   |
| Energy and Lighting           | <a href="http://www.ti.com/energy">www.ti.com/energy</a>                                 |
| Industrial                    | <a href="http://www.ti.com/industrial">www.ti.com/industrial</a>                         |
| Medical                       | <a href="http://www.ti.com/medical">www.ti.com/medical</a>                               |
| Security                      | <a href="http://www.ti.com/security">www.ti.com/security</a>                             |
| Space, Avionics and Defense   | <a href="http://www.ti.com/space-avionics-defense">www.ti.com/space-avionics-defense</a> |
| Video and Imaging             | <a href="http://www.ti.com/video">www.ti.com/video</a>                                   |

### TI E2E Community

[e2e.ti.com](http://e2e.ti.com)