

Features

Platform Cable USB has these features:

- Supported on Windows and Red Hat Enterprise Linux
 - Automatically senses and adapts to target I/O voltage
 - Interfaces to devices operating at 5V (TTL), 3.3V (LVCMOS), 2.5V, 1.8V, and 1.5V
 - LED Status Indicator
 - CE, USB-IF, and FCC compliant
 - Intended for development — not recommended for production programming
 - Pb-free (RoHS-compliant)
- Configures all Xilinx devices
 - ◆ All Virtex™ FPGA families
 - ◆ All Spartan™ FPGA families
 - ◆ XC9500 / XC9500XL / XC9500XV CPLDs
 - ◆ CoolRunner™ XPLA3 / CoolRunner-II CPLDs
 - ◆ XC18V00 ISP PROMs
 - ◆ XCF00S / XCF00P Platform Flash PROMs
 - ◆ XC4000 series FPGAs
 - Programs serial peripheral interface (SPI) flash PROMs

Platform Cable USB Description

Platform Cable USB (Figure 1) is a high-performance download cable attaching to user hardware for the purpose of programming or configuring any of the following Xilinx devices:

- ISP Configuration PROMs
- CPLDs
- FPGAs

Platform Cable USB attaches to the USB port on a desktop or laptop PC with an off-the-shelf Hi-Speed USB A-B cable. It derives all operating power from the hub port controller. No external power supply is required. A sustained slave-serial FPGA configuration transfer rate of 24 Mb/s is possible in a Hi-Speed USB environment. Actual transfer rates can vary if bandwidth of the hub is being shared with other USB peripheral devices.

Device configuration and programming operations using Platform Cable USB are supported by iMPACT download software using boundary-scan (IEEE 1149.1 / IEEE 1532), slave-serial mode, or serial peripheral interface (SPI). Target clock speeds are selectable from 750 kHz to 24 MHz.

Platform Cable USB attaches to target systems using a 14-conductor ribbon cable designed for high-bandwidth data transfers. An optional adapter that allows attachment of a flying lead set is included for backward compatibility with target systems that do not use the ribbon cable connector.

Physical Description

The Platform Cable USB electronics are housed in a recyclable, fire-retardant plastic case (Figure 2). An internal EMI shield attenuates internally generated emissions and protects against susceptibility to radiated emissions.



DS300_01_081006

Figure 1: Xilinx Platform Cable USB

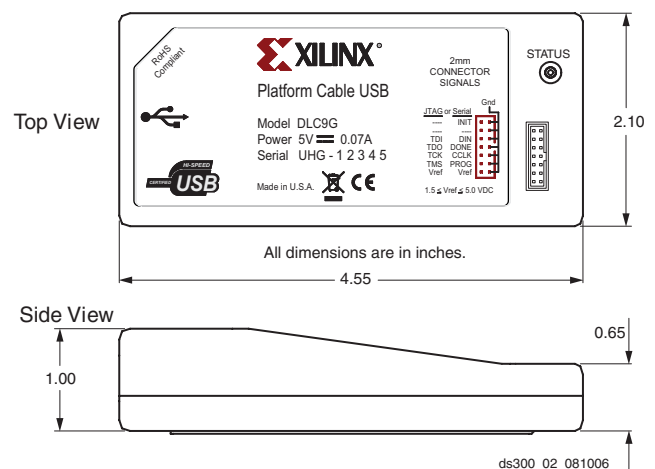

Figure 2: Plastic Case Physical Dimensions

Operation

This section describes how to connect and use Platform Cable USB.

Minimum Host Computer Requirements

The host computer must contain a USB Host Controller with one or more USB ports. The controller can reside on the PC motherboard, or can be added using a PCI expansion card or PCMCIA card.

Platform Cable USB is supported on systems that meet the Xilinx ISE™ system requirements. For environmental details, go to:

http://www.xilinx.com/products/design_resources/design_tool/index.htm

and select the ISE tool of choice. Platform Cable USB is designed to take full advantage of the bandwidth of USB 2.0 ports, but it is also backward-compatible with USB 1.1 ports. Refer to "Hub Types and Cable Performance," page 15 for additional information on connection environments and bandwidth.

Operating Power

Platform Cable USB is a bus-powered device that draws less than 100 mA from the host USB port under all operating conditions, automatically adapting to the capabilities of the host USB port to achieve the highest possible performance.

Platform Cable USB enumerates on any USB port type (for example, USB ports on root hubs, external bus-powered hubs, or external self-powered hubs), including legacy USB 1.1 hubs. However, performance is not optimal when attached to USB 1.1 hubs (refer to "Hot Plug and Play," page 4 for an explanation of USB enumeration.).

Note: The DLC9G and legacy DLC9LP cable models draw less than 100 mA from the host USB port. The legacy DLC9 cable model requires 230 mA to operate in USB 2.0 Hi-Speed mode or 150 mA to operate in USB 2.0/1.1 full-speed mode. Some older root hubs or external bus-powered hubs might restrict devices to 100 mA. The legacy DLC9 cable model does not enumerate on hubs with the 100 mA restriction.

Device Driver Installation

A proprietary device driver is required to use Platform Cable USB. Xilinx ISE software releases and service packs incorporate this device driver beginning with version 6.3.03i for the Windows operating system or 7.1i for the Linux operating system. Platform Cable USB is not recognized by the operating system until an appropriate Xilinx ISE, ChipScope™ Pro or Platform Studio (EDK) software installation has been completed.

Refer to [UG344](#), *USB Cable Installation Guide*, for a complete guide to installation of the Platform Cable USB and its device drivers.

Firmware Updates

Platform Cable USB is a RAM-based product. Application code is downloaded each time the cable is detected by the host operating system. USB protocol guarantees that the code is successfully downloaded.

All files necessary for successful cable communication are included with every Xilinx ISE software installation CD. Revised application code is periodically distributed in subsequent software releases. ISE Service Pack and WebPACK™ releases can be downloaded from www.xilinx.com. Project Navigator automatically checks for new releases when an Internet connection is detected.

When Xilinx applications are invoked and a connection is established with Platform Cable USB, version information for several software components is displayed in a command log.

Platform Cable USB also contains an embedded in-circuit programmable CPLD. Each time a Xilinx application is invoked, the firmware version for the CPLD is examined. The CPLD is automatically reprogrammed over the cable if the firmware version is out of date (see [Figure 3](#)).

Although a rare event, when CPLD reprogramming is necessary, the CPLD reprogramming process can take considerable time and must not be interrupted once started. The reprogramming time via a USB 2.0 port can typically take 10 to 15 minutes. Reprogramming time varies depending on the ISE software version, the type of USB port, and the performance of the host system. Later versions of the ISE software can reprogram CPLDs faster than older versions.

During a CPLD update, the Status LED illuminates red, and a progress bar indicates communication activity (see [Figure 4](#)). CPLD updates should never be interrupted. When an update is complete, the Status LED returns to either amber or green, and the cable is ready for normal operation.

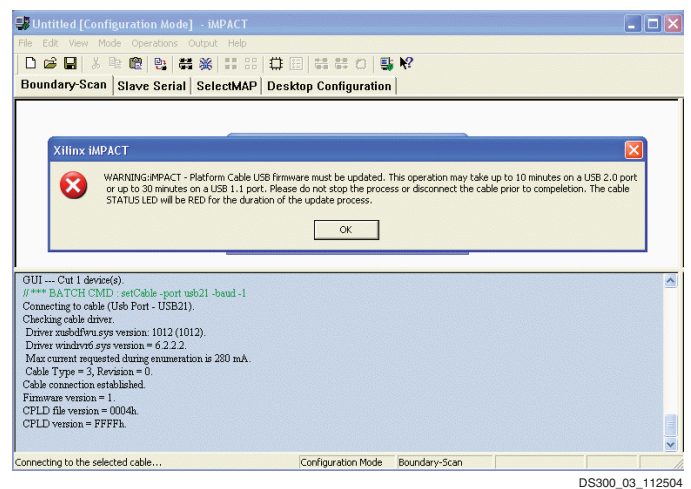

Figure 3: CPLD Update Notification

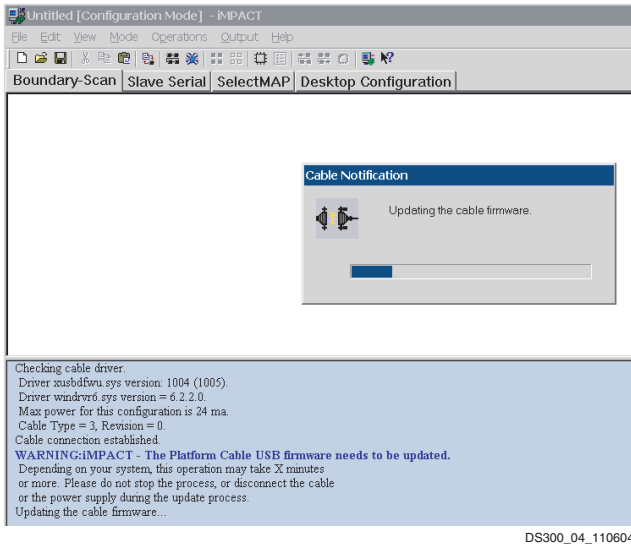

Figure 4: CPLD Update Progress Bar

Found New Hardware Wizard (for Windows Only)

Platform Cable USB should be disconnected from the host system during the initial software installation. The first time a cable is attached after software installation, Windows invokes the Found New Hardware wizard and registers device drivers for the Platform Cable USB Firmware Loader (see Figure 5) and for the Platform Cable USB itself (see Figure 6).

Windows invokes the Found New Hardware flow each time Platform Cable USB is plugged into a different physical USB port for the first time. The wizard screens could be slightly different for Windows 2000 environments.

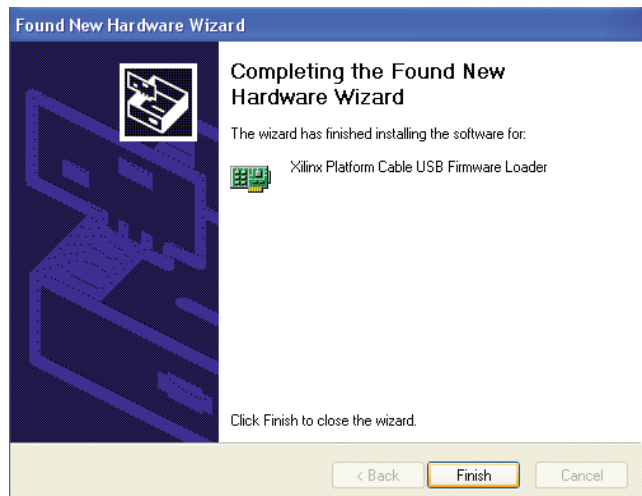
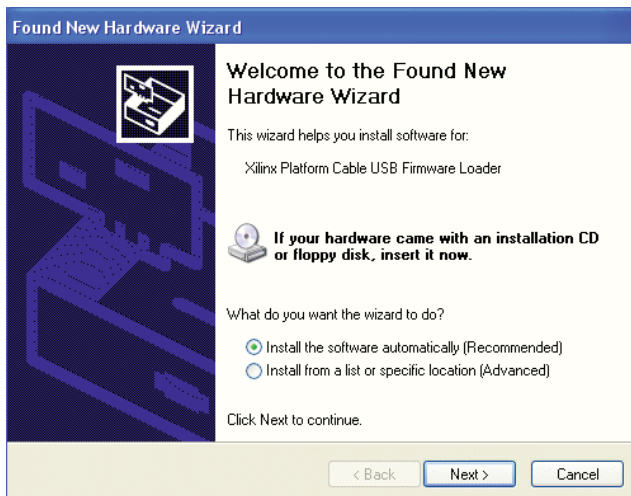

Figure 5: a) Firmware Loader PID Detected; b) Firmware Loader Driver Registered

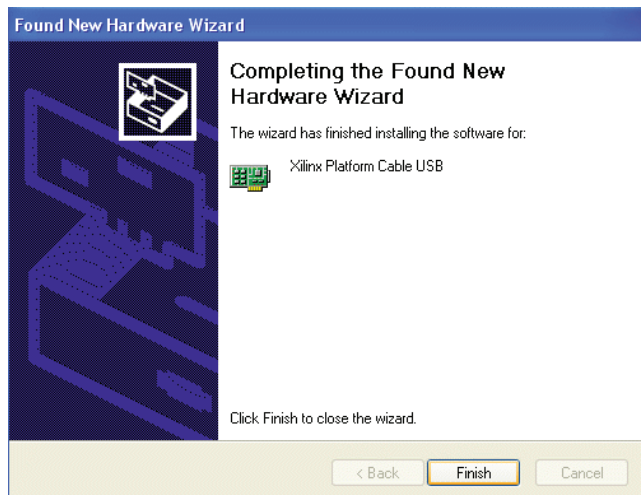
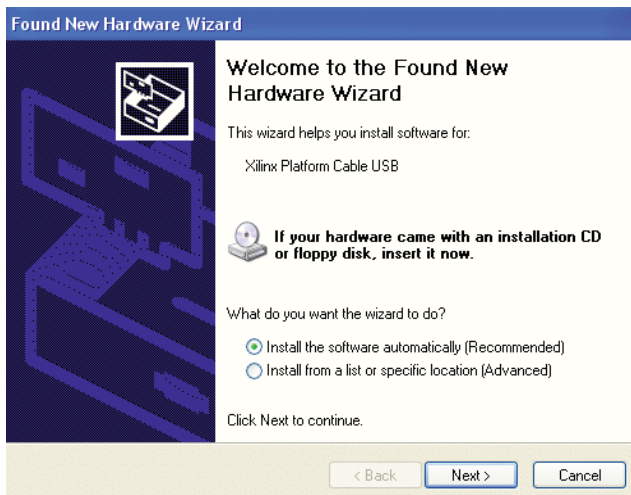

Figure 6: a) Application PID Detected; b) Application Driver Registered

Hot Plug and Play

The cable can be attached and removed from the host computer without the need to power-down or reboot. There is a momentary delay after connecting the cable to an available port before the Status LED illuminates. This process is called *enumeration*.

When Platform Cable USB completes the enumeration process on a Windows system, a "Programming cables" entry appears in the Windows Device Manager (see Figure 7). To display Device Manager, right-click on **My Computer**, then select **Properties** → **Hardware** → **Device Manager**.

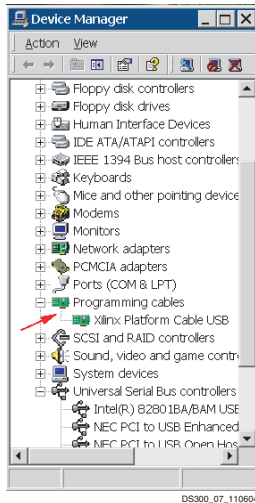

Figure 7: Device Manager Cable Identification

iMPACT Configuration Cable Selection

Platform Cable USB can be designated as the "active" configuration cable by following the auto-connect sequence for configuring devices that is displayed when first starting an iMPACT session.

Note: During the auto-connect sequence, iMPACT selects PC4 as the "active" cable if both PC4 and Platform Cable USB are connected simultaneously.

Alternatively, the cable can be manually selected using the **Output**→**Cable Setup** option on the iMPACT toolbar (see Figure 8).

When the *Cable Communications Setup* dialog box is displayed (Figure 9), the **Communication Mode** radio button must be set to "Platform Cable USB."

Before switching from the 'Boundary-Scan' mode to the 'Slave Serial' mode or vice versa, use **Output**→**Cable Disconnect**. After the mode switch is complete, reestablish the cable connection using the **Output**→**Cable Setup** dialog.

If an iMPACT session is active when the cable is removed, the Status bar immediately indicates "No Connection."

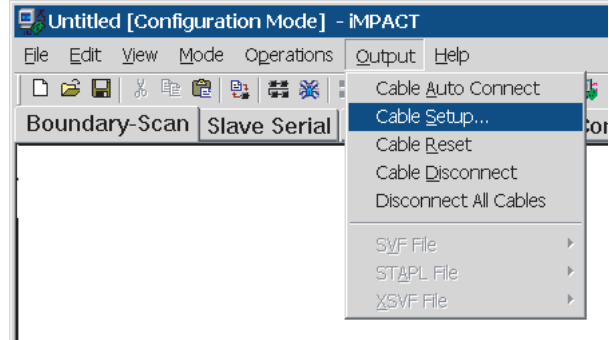

Figure 8: iMPACT Cable Selection Drop-Down Menu

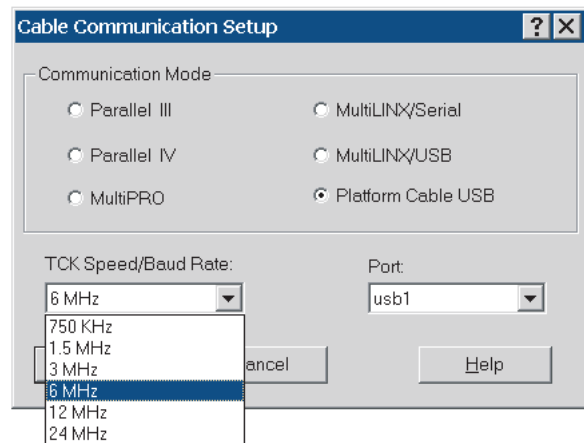

Figure 9: iMPACT Cable Communication Setup Dialog

Configuration Clock Speed

The Platform Cable USB configuration clock (TCK_CCLK_SCK) frequency is selectable. Table 1 shows the complete set of available TCK_CCLK_SCK speed selections for high-power USB ports.

Table 1: Speed Selection for High-Power Ports

| Selection | TCK_CCLK_SCK Frequency | Units |
|-------------|------------------------|-------|
| 1 | 24 | MHz |
| 2 | 12 | MHz |
| 3 (default) | 6 | MHz |
| 4 | 3 | MHz |
| 5 | 1.5 | MHz |
| 6 | 750 | kHz |

In slave-serial or SPI mode, the TCK_CCLK_SCK speed can be set to any one of the available selections. By default, the TCK_CCLK_SCK speed is set to 6 MHz. Users should take care to select a TCK_CCLK_SCK frequency that

matches the slave-serial clock (CCLK or SPI clock) specification of the target device.

In boundary-scan mode, iMPACT 7.1i (and later) queries the BSDL file of each device in a target boundary-scan chain to determine the maximum boundary-scan clock (JTAG TCK) frequency. iMPACT 7.1i (and later) automatically restricts the available TCK_CCLK_SCK selections to frequencies that are less than or equal to the slowest device in the chain. By default, iMPACT 7.1i (or later) selects either 6 MHz or the highest common frequency when any device in the boundary-scan chain is not capable of 6 MHz operation. Table 2 shows the maximum supported JTAG TCK frequency for a variety of Xilinx devices. See the device data sheet or BSDL file for maximum JTAG TCK specifications.

Note: iMPACT versions earlier than 7.1i do not restrict the TCK_CCLK_SCK selections in boundary-scan mode. Accordingly, users should take care to select a TCK_CCLK_SCK frequency that matches the JTAG TCK specifications for the slowest device in the target boundary-scan chain.

Table 2: Maximum JTAG Clock Frequencies

| Device Family | Maximum JTAG Clock Frequency | Units |
|---------------|------------------------------|-------|
| XC9500/XL/XV | 10 | MHz |
| XPLA3 | 10 | MHz |
| CoolRunner-II | 33 | MHz |
| XC18V00 | 10 | MHz |
| XCF00S/XCF00P | 15 | MHz |
| Virtex | 33 | MHz |
| Virtex-II | 33 | MHz |
| Virtex-II Pro | 33 | MHz |
| Virtex-4 | 33 | MHz |
| Virtex-5 | 33 | MHz |
| Spartan | 5 | MHz |
| Spartan-II | 33 | MHz |
| Spartan-3 | 33 | MHz |
| Spartan-3A | 10 | MHz |
| Spartan-3E | 10 | MHz |

A Status bar on the bottom edge of the iMPACT GUI provides useful information about operating conditions. If the host port is USB 1.1, Platform Cable USB connects at full-speed, and the Status bar shows "usb-fs." If the host port is USB 2.0, Platform Cable USB connects at Hi-Speed and the Status bar shows "usb-hs."

The active TCK_CCLK_SCK frequency is shown in the lower right-hand corner of the Status bar (see Figure 10).

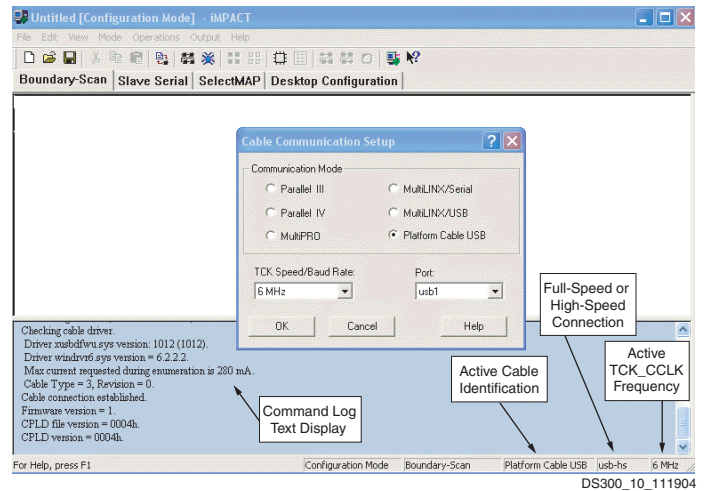

Figure 10: iMPACT Status Bar

The command log also includes information about communication with the cable. When the cable is selected using the *Cable Communication Setup* dialog box, the command log indicates:

```
Firmware version = 1
CPLD file version = 0004h
CPLD version = 0004h
Cable Connection Established
```

Note: The actual revision number can be expected to change with new software releases.

Status Indicator

Platform Cable USB uses a bi-color Status LED to indicate the presence of target voltage. When the ribbon cable is connected to a mating connector on the target system, the Status LED is illuminated as a function of the voltage present on pin 2 (V_{REF}).

Users must design their system hardware with pin 2 attached to a voltage plane that supplies the JTAG, SPI, or slave-serial pins on the target device(s). Some devices have separate power pins for this purpose (V_{AUX}), while others have a common supply for both V_{CCIO} and the JTAG pins (TCK, TMS, TDI, and TDO). Refer to the target device Data Sheet for details on slave-serial or JTAG pins.

The Status LED is amber (see Figure 11) when *any one or more* of the following conditions exist:

- The ribbon cable is not connected to a target system
- The target system is not powered
- The voltage on the V_{REF} pin is $< +1.5V$.

The Status LED is green when *all* of the following conditions exist:

- The ribbon cable is connected to a target system
- The target system is powered
- The voltage on the V_{REF} pin is $\geq +1.5V$.

The Status LED is Off whenever Platform Cable USB enters a Suspend state, or is disconnected from a powered USB port.

Amber indicates no target voltage



Green indicates target voltage present



DS300_11_081006

Figure 11: Status LEDs Indicating Target Voltage

Suspend State

Every USB device, including Platform Cable USB, can be placed into a *Suspend state* by the host operating system. This can occur during *any* of the following usage scenarios:

- The **Suspend** function key on a laptop computer is pressed.
- The display panel of a laptop is placed in the closed position for transport while applications are running.
- There is an extended period of time without data transfer activity on the cable when connected to a battery-powered laptop.

- There is an extended period of time without data transfer activity on the cable when connected to a desktop PC configured with an "Energy Efficiency" option.

The purpose of the Suspend state is to reduce overall power consumption. Suspend requests can be either global or port-specific.

Platform Cable USB must consume less than 500 μ A from the hub port when it enters the Suspend state. Consequently, the Status LED is turned off and remains off until commanded to resume.

If an iMPACT operation is in progress when Suspend is attempted, iMPACT displays a message indicating that Suspend is blocked until the operation is complete or is prematurely terminated (Figure 12).

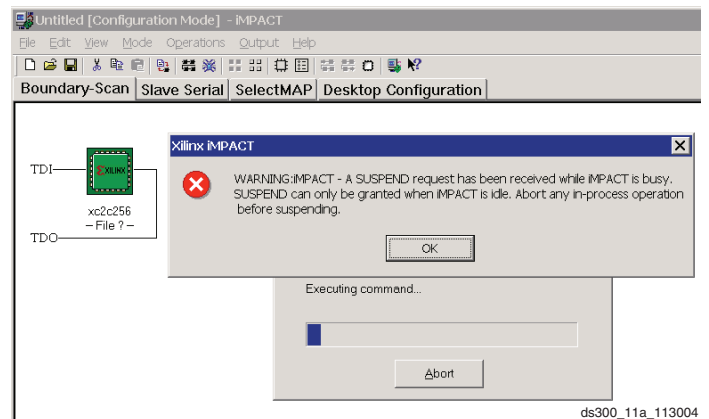

ds300_11a_113004

Figure 12: Suspend Warning When iMPACT Is Busy

The target interface logic, including drivers for TCK_CCLK_SCK, TMS_PROG_SS, and TDI_DIN_MOSI, is not powered in the Suspend mode. These signals float to any DC bias level provided by the target hardware during Suspend.

Note: Some computers remove power entirely from the USB port in Suspend mode. This is equivalent to a physical disconnect of the cable. When operation resumes, it is necessary to manually re-establish a connection to the cable using the **Output** → **Cable Setup** toolbar selection.

Platform Cable USB Connections

This section of the data sheet discusses physical connections from Platform Cable USB to the host PC and the target system.

High-Performance Ribbon Cable

A 6" ribbon cable is supplied and recommended for connection to target systems (refer to Figure 13). The cable incorporates multiple signal-ground pairs and facilitates error-free connections.

To take advantage of the ribbon cable, a mating connector must be incorporated into the target system. This connector is normally installed only during prototype checkout. When the production hardware is functional and the ISP devices can be configured from alternate sources, the connector can be eliminated as a cost reduction option. Maintaining the footprint for this connector is a wise choice if space permits.

The connector is a 2 mm shrouded keyed header. See "Target Interface Connectors," page 8 for vendor part numbers and pin assignments.

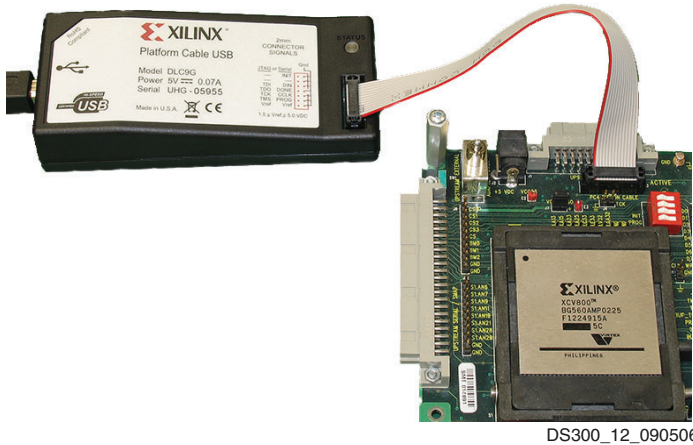

Figure 13: High-Performance Ribbon Cable

Notes:

1. Ribbon Cable: 14 conductor, 1.0 mm center, round conductor flat cable, 28 AWG (7x36) stranded conductors, gray PVC with pin 1 edge marked.
2. 2 mm ribbon female polarized connector, IDC connection to ribbon. Contacts are beryllium copper plated, 30 micro-inches gold plating over 50 micro-inches nickel. The connectors mate to 0.5 mm square posts on 2 mm centers.

Flying Wire Adapter

An adapter is provided for attachment to legacy target systems that do not incorporate a shrouded male 2 mm connector (Figure 14). The adapter makes it possible to use

flying wires for connection to distributed terminals on a target system.

The adapter is a small circuit board with two connectors (Figure 15). The connector on the bottom side of the adapter mates with the 14-pin Platform Cable USB male 2 mm connector. A 7-pin right-angle header on the top side of the adapter mates with the standard Xilinx flying wire set (included).

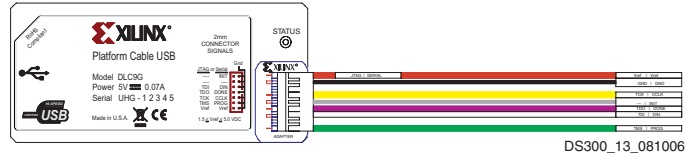

Figure 14: Flying Wire Adapter (Top) with Wires

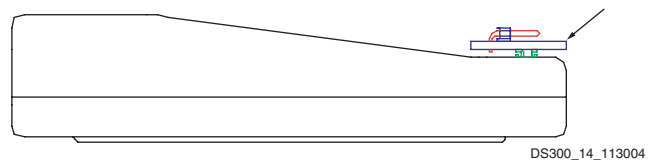

Figure 15: Flying Wire Adapter (Side) w/o Wires

Note: This method of connection is not recommended because it can result in poor signal integrity. Additionally, damage can result if the leads are unintentionally connected to high voltages.

Physical Connection to the Host

Each Platform Cable USB includes a detachable, Hi-Speed certified 1.8 meter A-B cable (Figure 16). Under no circumstances should user-supplied cables exceed 5 meters. Sub-channel cables (intended for low-speed 1.5 Mb/s signaling) should not be used with Platform Cable USB.

A standard series B receptacle is incorporated into the left side of the case for mating with the detachable Hi-Speed A-B cable. A separate chassis ground is attached to the A-B cable drain wire and returns ESD current to the host system ground.

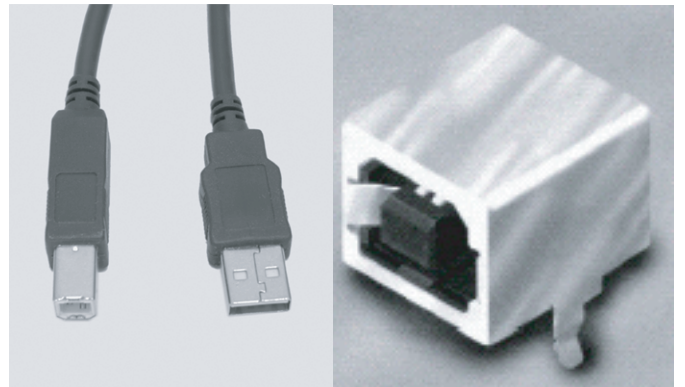

Figure 16: Standard A-B Host Interface Cable and Series B Receptacle

Target Interface Connectors

Mating connectors for attachment of the high-performance ribbon cable to a target system are available in both through-hole and surface mount configurations (Figure 17). Shrouded and/or keyed versions should always be used to guarantee proper orientation when inserting the cable. The connector requires only 0.162 in² of board space.

The target system voltage applied to pin 2 of this connector is used as a reference for the output buffers that drive the TDI_DIN_MOSI, TCK_CCLK_SCK, and TMS_PROG_SS pins. Table 3 provides some third-party sources for mating connectors that are compatible with the Platform Cable USB ribbon cable.

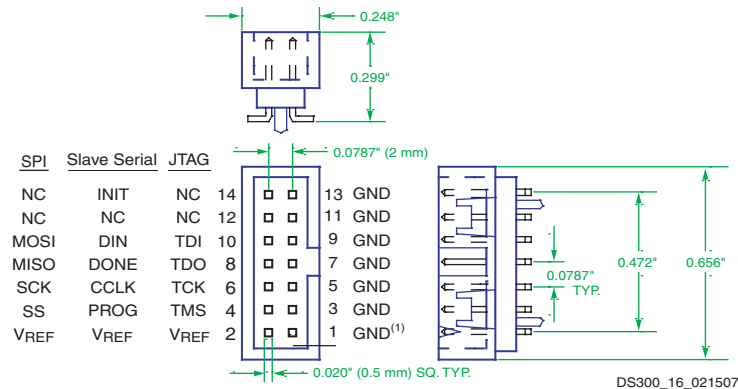

Figure 17: Target Interface Connector Dimensions and Signal Assignments

Table 3: Mating Connectors for 2 mm pitch, 14-Conductor Ribbon Cable

| Manufacturer ⁽¹⁾ | SMT, Vertical | Through-Hole, Vertical | Through-Hole, Right Angle | Web Site |
|-----------------------------|---------------|------------------------|---------------------------|--|
| Molex | 87832-1420 | 87831-1420 | 87833-1420 | www.molex.com |
| FCI | 98424-G52-14 | 98414-G06-14 | 98464-G61-14 | www.fciconnect.com |
| Comm Con Connectors | 2475-14G2 | 2422-14G2 | 2401R-G2-14 | www.commcon.com |

Notes:

1. Some manufacturer pin assignments do not conform to Xilinx pin assignments. Please refer to the manufacturer’s data sheet for more information.
2. Additional ribbon cables can be purchased separately from the [Xilinx Online Store](http://www.xilinx.com).

TDI_DIN_MOSI and TMS_PROG_SS Timing Specifications

For JTAG, SPI, and slave-serial configuration modes, the TDI_DIN_MOSI and TMS_PROG_SS outputs change on falling edges of TCK_CCLK_SCK (Figure 18). Target devices sample TDI_DIN_MOSI and TMS_PROG_SS on rising edges of TCK_CCLK_SCK. The minimum setup time $T_{TTSU(MIN)}$ for target device sampling of TDI_DIN_MOSI or TMS_PROG_SS is:

$$\begin{aligned} T_{TTSU(MIN)} &= T_{CLK/2} - T_{CPD(MAX)} \\ &= 20.83 \text{ ns} - 9.2 \text{ ns} \\ &= 11.63 \text{ ns} \end{aligned}$$

where $T_{CLK/2}$ is the TCK_CCLK_SCK Low time at 24 MHz, and $T_{CPD(MAX)}$ is the maximum TDI_DIN_MOSI or TMS_PROG_SS propagation delay relative to TCK_CCLK_SCK inherent in the output stage of the cable. Reducing the TCK_CCLK_SCK frequency increases the data setup time at the target.

Note: Timing specifications apply when VREF = 3.3V. Operation at 24 MHz might not be possible when using a VREF below 3.3V due to the increased propagation delay through the output buffer stage of the cable.

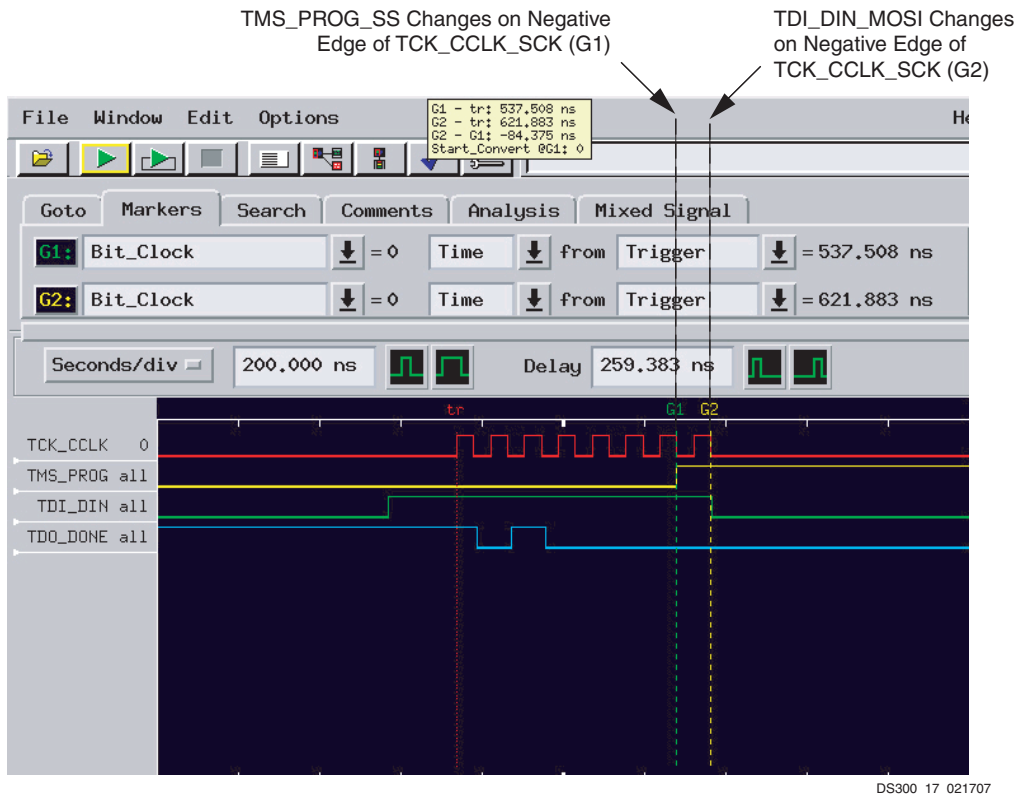

Figure 18: TDI_DIN_MOSI and TMS_PROG_SS Timing with Respect to TCK_CCLK_SCK

TDO/MISO Timing Issues

When read operations are being performed in Boundary-Scan or SPI mode, there must be sufficient time during each one-half clock cycle for TDO/MISO to propagate back to the cable for sampling. Figure 19, Figure 20, page 10, and Figure 21, page 10 illustrate a potential problem when a 24 MHz TCK_CCLK_SCK frequency is selected. An output buffer in Platform Cable USB introduces a phase delay of 4 ns between the cable and the target. (See cursors C1 and C2 in Figure 19, page 10 for the CBL_TCK to TCK_CCLK_SCK delay.)

The target device has a variable propagation delay from the negative edge of TCK_CCLK_SCK to assertion of TDO_DONE_MISO. (Refer to Figure 20 for the TCK_CCLK_SCK to TDO_DONE_MISO delay.) For

example, Figure 20 shows a 12 ns TDO delay for an XC2C256-VQ100 CPLD.

Finally, signal conditioning circuitry in Platform Cable USB introduces a third-phase delay of approximately 12 ns between TDO_DONE_MISO and the logic that samples the signal.

Note: (Refer to Figure 21, page 10 for the TDO_DONE_MISO to CBL_TDO delay.)

Data is sampled approximately 11 ns after the rising edge of CBL_TCK. The total propagation delay must be carefully considered to successfully operate at 24 MHz. Refer to Figure 30, page 18 for set-up timing requirements.

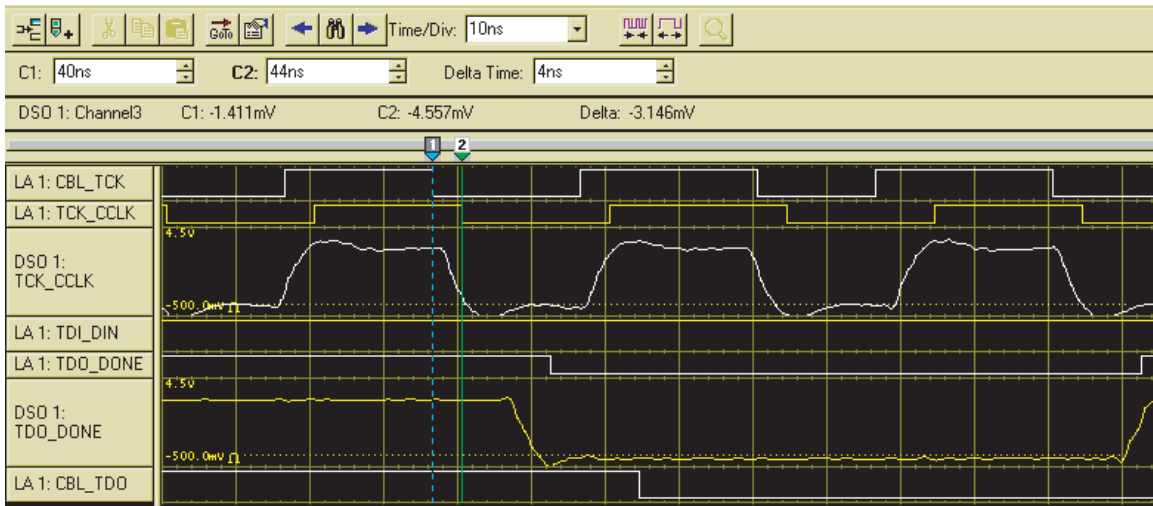

DS300_18_110204

Figure 19: TDO_DONE_MISO Timing with Respect to TCK_CCLK_SCK (CBL_TCK to TCK_CCLK_SCK Delay)

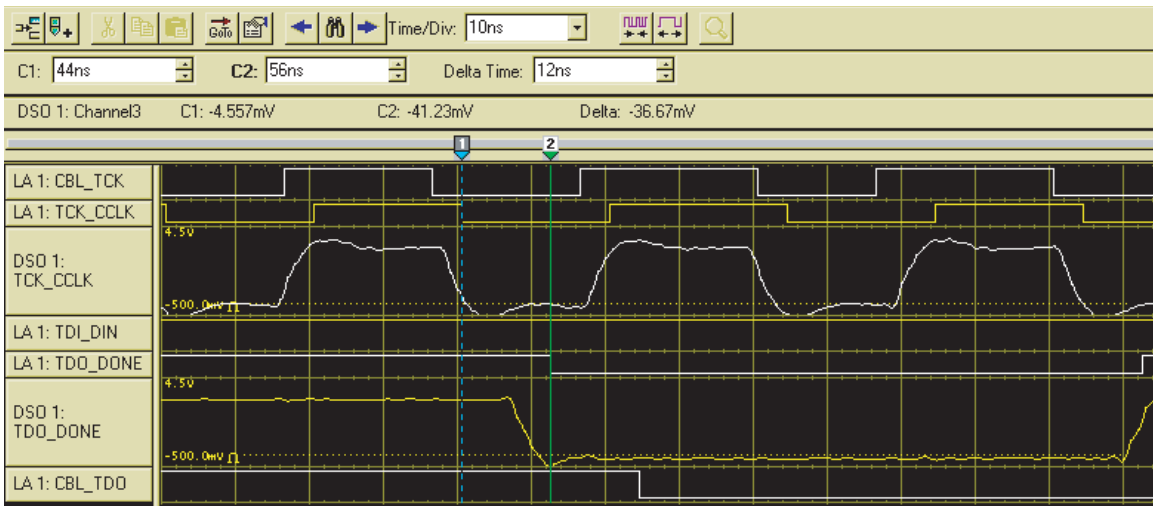

DS300_19_110204

Figure 20: TDO_DONE_MISO Timing with Respect to TCK_CCLK_SCK (TCK_CCLK_SCK to TDO_DONE_MISO Delay)



DS300_20_110204

Figure 21: TDO_DONE_MISO Timing with Respect to TCK_CCLK_SCK (TDO_DONE_MISO to CBL_TDO Delay)

Target Reference Voltage Sensing (V_{REF})

Platform Cable USB incorporates an over-voltage clamp on the V_{REF} pin of the 2 mm ribbon cable connector. The clamped voltage (V_{REF_A}) supplies a high-slew-rate buffer (NC7SZ125) that drives each of the three output signals. V_{REF} must be a regulated voltage.

Note: Do not insert a current-limiting resistor in the target system between the V_{REF} supply and pin 2 on the 2 mm connector.

No damage to Platform Cable USB occurs if the A-B cable is unplugged from the host while the ribbon cable or flying leads are attached to a powered target system. Similarly, no damage to target systems occurs if Platform Cable USB is powered and attached to the target system while the target system power is off.

Buffers for the output signals (TCK_CCLK_SCK, TMS_PROG_SS, and TDI_DIN_MOSI) are set to high-Z when V_{REF} drops below 1.40V. The output buffer amplitude linearly tracks voltage changes on the V_{REF} pin when $1.40V \leq V_{REF} \leq 3.30V$. Amplitude is clamped at approximately 3.30V when $3.30 \leq V_{REF} \leq 5.00V$.

Refer to Table 4 for the relationship between V_{REF} voltage and output signal amplitude.

Table 4: Output Signal Level as a Function of the V_{REF}

| V_{REF} Voltage on Target System (VDC) | Output Signal Levels (VDC) | Status LED Color |
|--|----------------------------|------------------|
| $0.00 \leq V_{REF} < 1.40$ | High-Z | Amber |
| $1.40 \leq V_{REF} < 3.30$ | V_{REF} | Green |
| $3.30 \leq V_{REF} \leq 5.00$ | $\cong 3.3$ | Green |

Notes:

- There are weak pull-up resistors to V_{REF_A} on each of the three output drivers (TCK_CCLK_SCK, TMS_PROG_SS, and TDI_DIN_MOSI). The output drivers are active only during configuration and programming operations. Between operations, the drivers are set to high-Z.

Xilinx applications actively drive the outputs to Logic 1 before setting the respective buffer to high-Z. This avoids the possibility of a slow rise-time transition caused by a charge path through the pull-up resistor into parasitic capacitance on the target system.

Output Driver Structure

Platform Cable USB drives three target signals: TCK_CCLK_SCK, TMS_PROG_SS, and TDI_DIN_MOSI. Each of these signals incorporates the same driver topology. A Xilinx XC2C256 Coolrunner-II CPLD generates the output signals.

Each signal is routed to an external NC7SZ125 high-speed CMOS buffer (Figure 22). Series-damping resistors (30Ω) reduce reflections. Weak pull-up resistors (20 kΩ) maintain a defined logic level when the buffers are set to high-Z. The pull-up resistors terminate to V_{REF_A} .

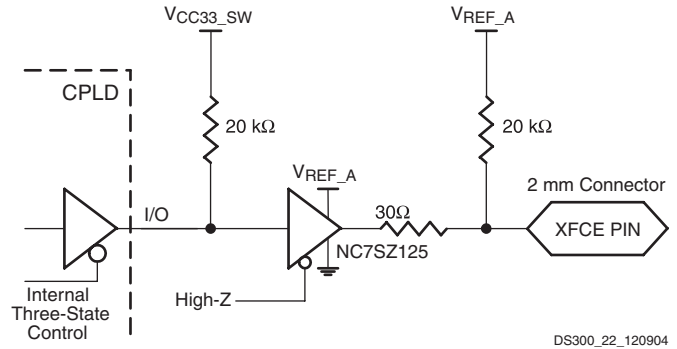

Figure 22: Target Interface Driver Topology

Refer to Figure 23 to determine the expected value of V_{REF_A} as a function of V_{REF} .

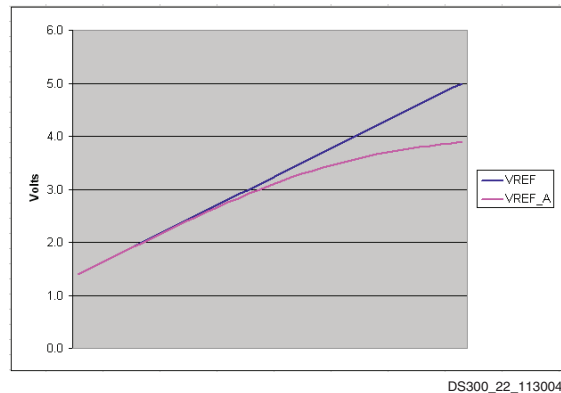

Figure 23: V_{REF_A} as a Function of V_{REF}

Input Receiver Structure

A Schottky diode is used to protect the TDO_DONE_MISO voltage comparator (Figure 24, page 12). In effect, Platform Cable USB looks for voltages below V_{IL_MAX} to detect logic 0, and tolerates voltages much higher than V_{REF_A} because TDO could be terminated to a supply other than V_{REF} .

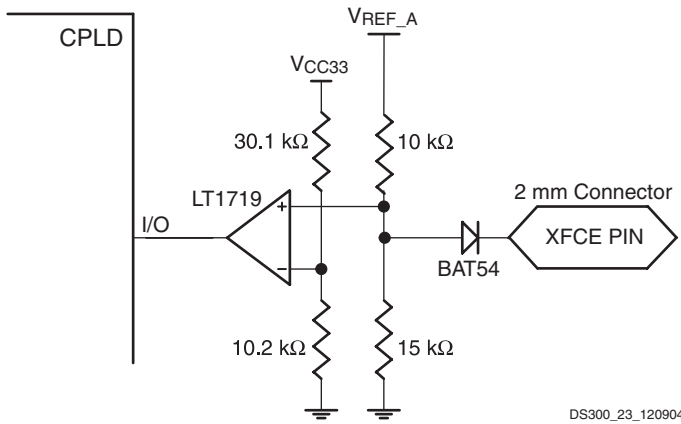

Figure 24: Target Interface Receiver Topology

Signal Integrity

Platform Cable USB uses high-slew-rate buffers to drive TCK_CCLK_SCK, TMS_PROG_SS, and TDI_DIN_MOSI. Each buffer has a 30Ω series termination resistor. Users should pay close attention to PCB layout to avoid transmission line effects. Visit the Xilinx [Signal Integrity Central](#) website, and see specifically Xilinx Application Note [XAPP361, Planning for High Speed XC9500XV Designs](#), for detailed signal integrity assistance.

If the target system has only one programmable device, the 2 mm connector should be located as close as possible to the target device. If there are multiple devices in a single chain on the target system, users should consider buffering TCK_CCLK_SCK. Differential driver/receiver pairs provide excellent signal quality when the rules identified in

Figure 25 are followed. Buffering is essential if target devices are distributed over a large PCB area.

Each differential driver and/or receiver pair contributes approximately 5 ns of propagation delay. This is insignificant when using 12 MHz or slower clock speeds.

Each differential receiver can drive multiple target devices if there are no branches on the PCB trace and the total trace length is less than four inches. A series termination resistor should be placed adjacent to the single-ended output of the differential receiver.

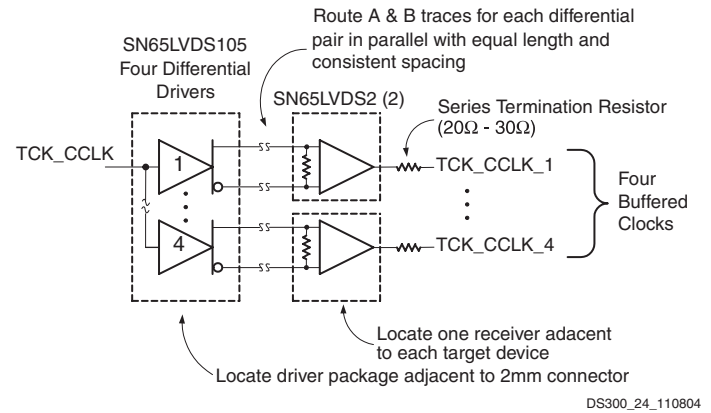

Figure 25: Differential Clock Buffer Example

Note: If the target system incorporates a buffer for TCK_CCLK_SCK and the 24 MHz clock rate is used, it is recommended that the same buffer type also be provided for TMS_PROG_SS. This maintains a consistent phase relationship between TCK_CCLK_SCK and TMS_PROG_SS. A buffer is not needed for TDI_DIN_MOSI, because it sees only one load.

Target System Connections

Multiple devices can be cascaded when using either JTAG or slave-serial topology in target systems. Figure 27 shows typical JTAG connections, and Figure 28, page 14 shows an example of slave-serial routing.

The Platform Cable USB can connect directly to a single SPI flash device. Figure 26 shows example SPI flash connections. Refer to [XAPP951](#), *Configuring Xilinx FPGAs with SPI Serial Flash*, for a detailed reference design showing the cable connections for programming an FPGA bitstream into a SPI flash device.

The DONE pin on FPGAs can be programmed to be an open-drain or active driver. For cascaded slave-serial topologies, an external pull-up resistor should be used, and all devices should be programmed for open-drain operation.

If the 2 mm connector is located a significant distance from the target device, it is best to buffer TCK_CCLK_SCK, at a minimum. These diagrams are intended to represent the logical relationship between Platform Cable USB and target devices. Refer to "Signal Integrity," page 12 for additional buffering and termination information.

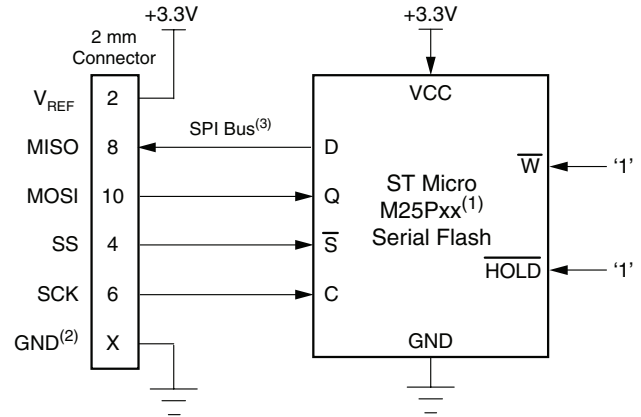

Notes:

1. The example shows pin names for an STMicrosystems M25Pxx serial flash device. SPI flash devices from other vendors can have different pin names and requirements. See the SPI flash data sheet for the equivalent pins and device requirements.
2. Attach the following 2 mm connector pins to digital ground: 1, 3, 5, 7, 9, 11, 13.
3. Typically, an FPGA and other slave SPI devices, which are not shown, are connected to the SPI bus. The other devices on the SPI bus must be disabled when the cable is connected to the 2 mm connector to avoid signal contention. When a Xilinx FPGA is connected to the SPI bus, the FPGA PROG_B pin can be held Low to ensure the FPGA pins are kept in a high-impedance state.

DS300_30_021607

Figure 26: Example of SPI Topology

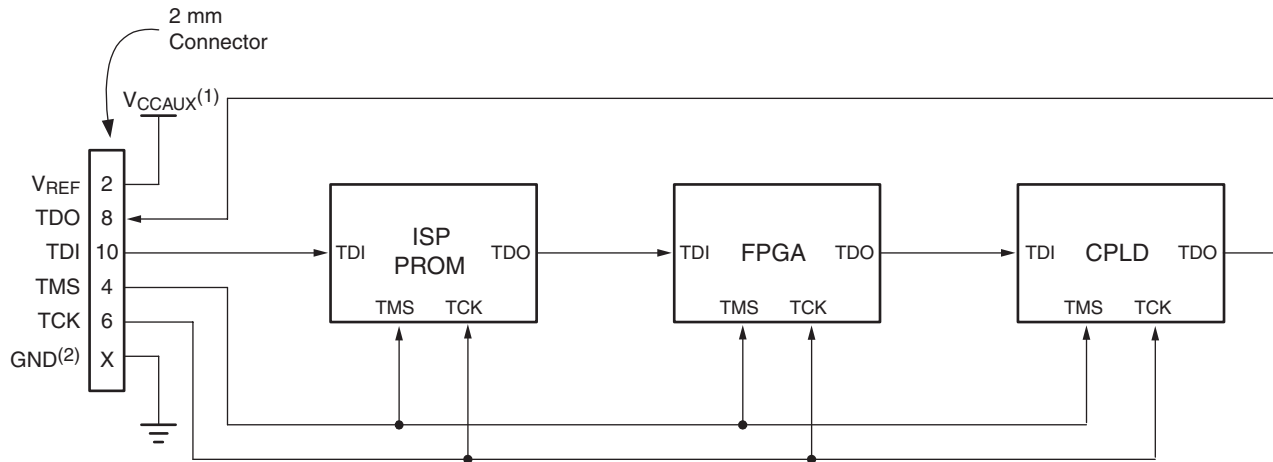

Notes:

1. Example implies that V_{CC0}, V_{CCJ}, V_{CC_CONFIG} and V_{CCAUX} for various devices are set to the same voltage. See device data sheets for appropriate JTAG voltage-supply levels.
2. Attach the following 2 mm connector pins to digital ground: 1, 3, 5, 7, 9, 11, 13.

DS300_26_031006

Figure 27: Example of JTAG Chain Topology

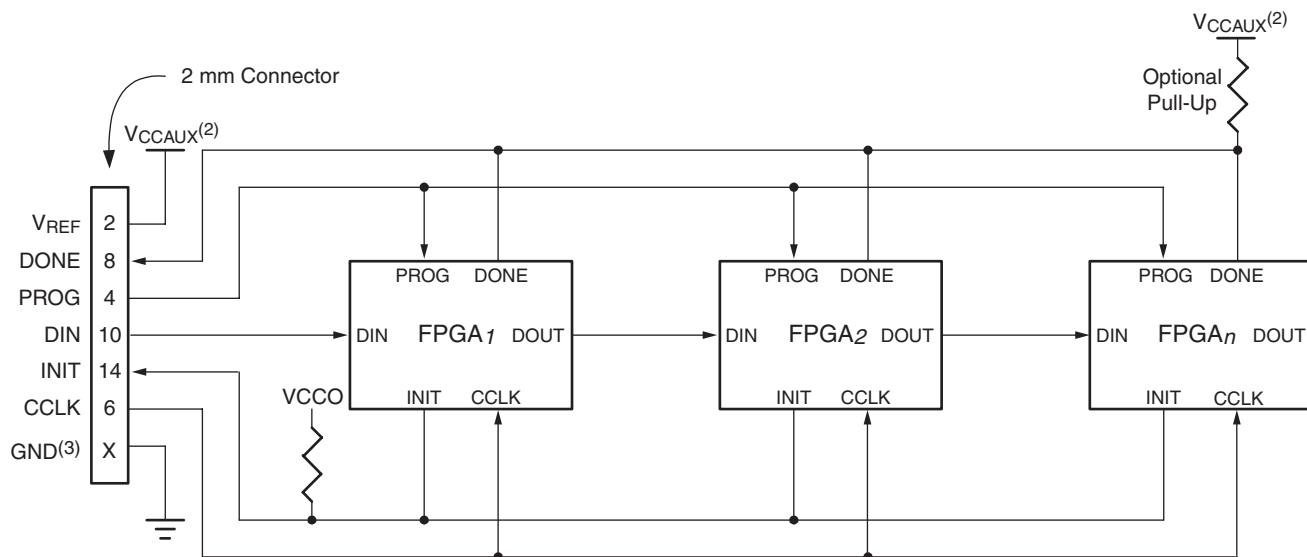

Notes:

1. Set Mode pins (M2-M0) on each FPGA to Slave-serial mode when using the USB cable, so that CCLK is treated as an input.
2. VCCAUX is 3.3V for Virtex-II FPGAs, 2.5V for Virtex-II Pro FPGAs, or 2.5V for Spartan-3/3E FPGAs. The VCCAUX for Spartan-3A FPGAs can be 2.5V or 3.3V. Virtex-4/5 serial configuration pins are on a dedicated VCC_CONFIG (VCCO_0), 2.5V supply. Other FPGA families do not have a separate VCCAUX supply.
3. Attach the following 2 mm connector pins to digital ground: 1, 3, 5, 7, 9, 11, 13.

DS300_25_021507

Figure 28: Example of Cascaded Slave-Serial Topology

Hub Types and Cable Performance

There are two important hub specifications that affect the performance of Platform Cable USB: maximum port current and total bandwidth.

Maximum Port Current

Platform Cable USB is a bus-powered device that draws less than 100 mA from the host USB port under all operating conditions.

Note: The DLC9G and legacy DLC9LP cable models draw less than 100 mA from the host USB port. The legacy DLC9 cable model requires 230 mA to operate in USB 2.0 Hi-Speed mode or 150 mA to operate in USB 2.0/1.1 full-speed mode. Some older root hubs or external bus-powered hubs might restrict devices to 100 mA. The legacy DLC9 cable model does not enumerate on hubs with the 100 mA restriction.

Total Bandwidth

The maximum achievable bandwidth for a single USB 1.1 full-speed device is 8 Mb/s. The maximum theoretical bandwidth for a single USB 2.0 Hi-Speed device is 56 Mb/s.

Because hub bandwidth must be shared among all connected devices, actual bandwidth could be lower.

If Platform Cable USB is attached to a 1.1 hub, configuration speed is degraded. Communication overhead and protocol limit any given device to approximately 30% of total bandwidth. For 1.1 hubs, the best achievable throughput is approximately 3.6 Mb/s (refer to Figure 29).

If an external 2.0 hub is attached to a 1.1 root hub, operation is at full speed (refer to Figure 29B). Hi-Speed USB operation is guaranteed only if Platform Cable USB is attached directly to a 2.0 root hub, or to an external self-powered 2.0 hub that is connected to a 2.0 root hub (refer to Figure 29D and Figure 29E).

If Platform Cable USB is attached to an external, bus-powered 2.0 hub, it could enumerate as a full-speed device (refer to Figure 29C). Bus-powered hubs can deliver a total of 500 mA to all connected devices. If individual ports on bus-powered hubs are limited to less than 150 mA, Platform Cable USB does not enumerate and is unavailable for use by host software applications.

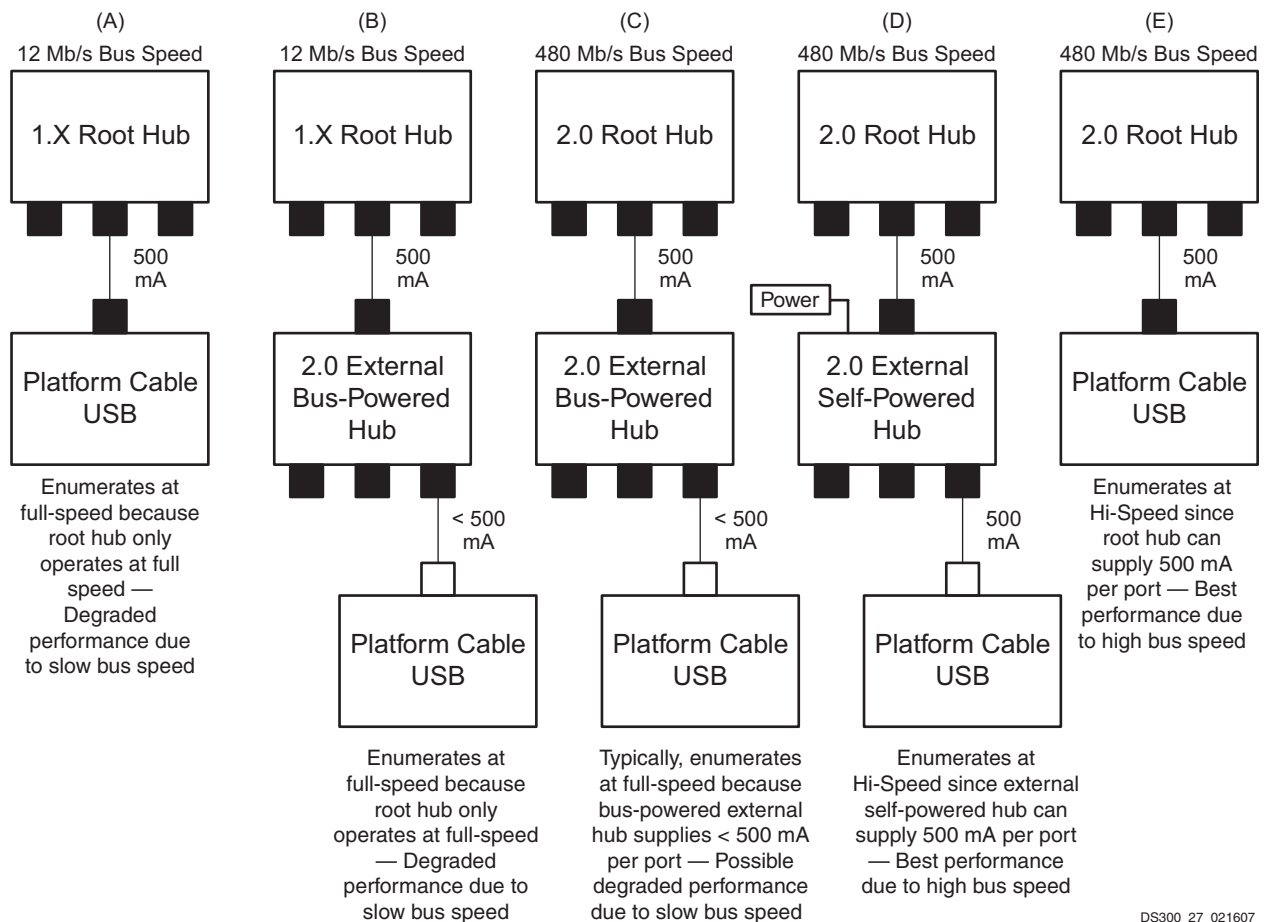

Figure 29: Platform Cable USB Performance with Various Hub Types

DS300_27_021607

Interface Pin Descriptions

Table 5: SS/JTAG/SPI Port: 14-Pin Ribbon Cable Connector

| Ribbon Cable Number | Slave-Serial Configuration Mode | JTAG Configuration Mode | SPI ⁽²⁾ Programming Mode | Type | Description |
|-----------------------|---------------------------------|-------------------------|-------------------------------------|-------|---|
| 2 | V _{REF} | V _{REF} | – | In | Target Reference Voltage. ⁽³⁾ This pin should be connected to a voltage bus on the target system that serves the JTAG, slave-serial interface, or SPI. For example, when programming a Coolrunner-II device using the JTAG port, V _{REF} should be connected to the target VAUX bus. |
| 4 | PROG | – | – | Out | Configuration Reset. This pin is used to force a reconfiguration of the target FPGA(s). It should be connected to the PROG_B pin of the target FPGA for a single-device system, or to the PROG_B pin of all FPGAs in parallel in a daisy-chain configuration. |
| 6 | CCLK | – | – | Out | Configuration Clock. FPGAs load one configuration bit per CCLK cycle in slave-serial mode. CCLK should be connected to the CCLK pin on the target FPGA for a single-device configuration, or to the CCLK pin of all FPGAs in parallel in a daisy-chain configuration. |
| 8 | DONE | – | – | In | Configuration Done. This pin indicates to Platform Cable USB that target FPGAs have received the entire configuration bitstream. It should be connected to the Done pin on all FPGAs in parallel for daisy-chained configurations. Additional CCLK cycles are issued following the positive transition of Done to insure that the configuration process is complete. |
| 10 | DIN | – | – | Out | Configuration Data Input. This is the serial input data stream for target FPGAs. It should be connected to the DIN pin of the target FPGA in a single-device system, or to the DIN pin of the first FPGA in a daisy-chain configuration. |
| 12 | N/C | N/C | – | – | Reserved. This pin is reserved for Xilinx diagnostics and should not be connected to any target circuitry. |
| 14 | INIT | – | – | BIDIR | Configuration Initialize. This pin indicates that configuration memory is being cleared. It should be connected to the INIT_B pin of the target FPGA for a single-device system, or to the INIT_B pin on all FPGAs in parallel in a daisy-chain configuration. |
| 4 | – | TMS | – | Out | Test Mode Select. This is the JTAG mode signal that establishes appropriate TAP state transitions for target ISP devices. It should be connected to the TMS pin on all target ISP devices that share the same data stream. |
| 6 | – | TCK | – | Out | Test Clock. This is the clock signal for JTAG operations, and should be connected to the TCK pin on all target ISP devices that share the same data stream. |
| 8 | – | TDO | – | In | Test Data Out. This is the serial data stream received from the TDO pin on the last device in a JTAG chain. |
| 10 | – | TDI | – | Out | Test Data In. This is the serial data stream transmitted to the TDI pin on the first device in a JTAG chain. |
| 10 | – | – | MOSI | Out | SPI Master-Output Slave-Input. This pin is the target serial input data stream for SPI operations and should be connected to the D ⁽²⁾ pin on the SPI flash PROM. |
| 8 | – | – | MISO | In | SPI Master-Input, Slave-Output. This pin is the target serial output data stream for SPI operations and should be connected to the Q ⁽²⁾ pin on the SPI flash PROM. |
| 6 | – | – | SCK | Out | SPI Clock. This pin is the clock signal for SPI operations and should be connected to the C ⁽²⁾ pin on the SPI flash PROM. |
| 4 | – | – | SS | Out | SPI Select. This pin is the active-Low SPI chip select signal. This should be connected to the S ⁽²⁾ pin on the SPI flash PROM. |
| 1, 3, 5, 7, 9, 11, 13 | – | – | – | – | Digital Ground. ⁽¹⁾ |

Notes:

- All odd pins (1, 3, 5, 7, 9, 11, and 13) should be connected to digital ground on the target end of the ribbon cable. Minimum crosstalk is achieved when using all grounds.
- The listed SPI pin names match those of SPI flash memories from STMicroelectronics. Pin names of compatible SPI devices from other vendors can be different. Consult the vendor's SPI device data sheet for corresponding pin names.
Caution! The PROG_B pin of the FPGA, which is connected to a target SPI device, must be asserted Low during SPI programming to ensure the FPGA does not contend with the SPI programming operation.
- The target reference voltage must be regulated and must not have a current-limiting resistor in series with the V_{REF} pin.

Platform Cable USB Operating Characteristics

Table 6: Absolute Maximum Ratings

| Symbol | Description | Conditions | Value | Units |
|------------|---|----------------------------------|-------|-------|
| V_{BUS} | USB Port Supply Voltage | | 5.25 | V |
| V_{REF} | Target Reference Voltage | | 6.00 | V |
| I_{REF} | Target Supply Current | $V_{REF} = 5.25V$ | 110 | mA |
| T_A | Operating Temperature | | 70 | °C |
| I_{CC1} | Dynamic Current ⁽¹⁾ | $V_{BUS} = 5.25V$; TCK = 24 MHz | 90 | mA |
| I_{CC2} | Dynamic Current ⁽²⁾ | $V_{BUS} = 5.25V$; TCK = 6 MHz | 75 | mA |
| I_{CCSU} | Suspend Current | $V_{BUS} = 5.25V$ | 350 | μA |
| I_{OUT} | DC Output Current (TCK_CCLK_SCK, TMS_PROG_SS, TDI_DIN_MOSI, and I _{INIT}) | | ±24 | mA |

Notes:

- Operating at Hi-Speed on a USB 2.0 port. The I_{CC1} value in the table applies to the DLC9G and legacy DLC9LP cable models. The legacy DLC9 cable model I_{CC1} value is 230 mA.
- Operating at full-speed on a low-power USB 1.1 port. The I_{CC2} table value applies to the DLC9G and legacy DLC9LP cable models. The legacy DLC9 cable model I_{CC2} value is 98 mA.
- Exposure to Absolute Maximum Rating conditions for extended periods of time can affect product reliability. These are stress ratings only and functional operation of the product at these or any other condition beyond those listed under Recommended Operating Conditions is not implied.

Table 7: Recommended DC Operating Conditions

| Symbol | Description | Conditions | Min | Max | Units |
|-----------|---------------------------|-------------------------------------|------|------|-------|
| V_{BUS} | USB Port Supply Voltage | | 4.00 | 5.25 | V |
| V_{REF} | Target Reference Voltage | | 1.5 | 5.00 | V |
| I_{REF} | Target Supply Current | $V_{REF} = 3.30V$ | 1 | 18 | mA |
| T_A | Operating Temperature | | 0 | 70 | °C |
| T_{SIG} | Storage Temperature | | -40 | +85 | °C |
| V_{OH} | High-Level Output Voltage | $V_{REF} = 3.3V$; $I_{OH} = -8$ mA | 3.0 | | V |
| V_{OL} | Low-Level Output Voltage | $V_{REF} = 3.3V$; $I_{OH} = 8$ mA | | 0.4 | V |
| V_{OH} | High-Level Output Voltage | $V_{REF} = 1.5V$; $I_{OH} = -8$ mA | 1.3 | | V |
| V_{OL} | Low-Level Output Voltage | $V_{REF} = 1.5V$; $I_{OH} = 8$ mA | | 0.4 | V |
| V_{IH} | High-Level Input Voltage | $V_{REF} = 1.5V$ | 1.2 | | V |
| V_{IL} | Low-Level Input Voltage | $V_{REF} = 1.5V$ | | 0.4 | V |

Table 8: AC Operating Characteristics

| Symbol | Description | Conditions | Min | Max | Units |
|-----------|---|---------------------------------|---------|-------|-------|
| T_{CLK} | Clock Period | TCK_CCLK_SCK_S CK frequency: | 750 kHz | 41.66 | |
| | | | 24 MHz | | 1333 |
| T_{CPD} | Cable Propagation Delay Time TDI_DIN_MOSI (TMS_PROG_SS) relative to the negative edge of TCK_CCLK_SCK @ 24 MHz | Target system V_{REF} : | 3.3V | | 9.2 |
| | | | 2.5V | | TBD |
| | | | 1.8V | | TBD |
| T_{TSU} | Target Setup Time TDI_DIN_MOSI (TMS_PROG_SS) relative to the positive edge of TCK_CCLK_SCK @ 24 MHz | Target system V_{REF} : | 3.3V | 11 | |
| | | | 2.5V | TBD | |
| | | | 1.8V | TBD | |
| T_{CSU} | Cable Setup Time TDO_DONE_MISO relative to the positive edge of TCK_CCLK_SCK @ 24 MHz | Target system V_{REF} : | 3.3V | 11 | |
| | | | 2.5V | TBD | |
| | | | 1.8V | TBD | |
| T_{TPD} | Target Propagation Delay Time TDO_DONE_MISO relative to the negative edge of TCK_CCLK_SCK @ 24 MHz | Target system V_{REF} : | 3.3V | | 10 |
| | | | 2.5V | | TBD |
| | | | 1.8V | | TBD |

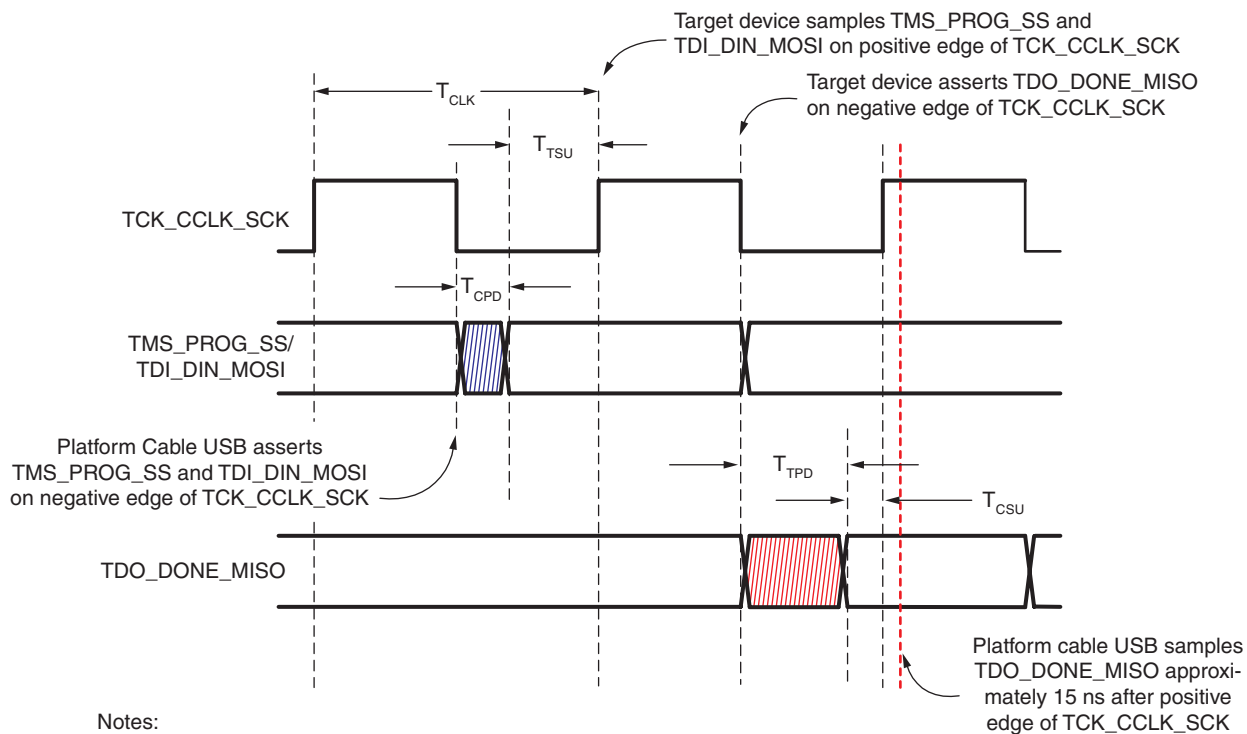

Notes:

1. All times are in nanoseconds and are relative to the target system interface connector.
2. T_{TSU} Min is the minimum setup time guaranteed by Platform Cable USB relative to the positive edge of TCK_CCLK_SCK.
3. T_{CSU} Min is the minimum setup required by Platform Cable USB to properly sample TDO_DONE_MISO.
4. Propagation delays associated with buffers on the target system must be taken into account to satisfy the minimum setup times.

DS300_28_021707

Figure 30: Platform Cable USB Timing Diagram

FCC Notice

This equipment has been tested and found to comply with the limits for a Class A digital device, pursuant to Part 15 of the FCC Rules. These limits are designed to provide reasonable protection against harmful interference when the equipment is operated in a commercial environment. This equipment generates, uses, and can radiate radio frequency energy and, if not installed and used in accordance with the data sheet, could cause harmful interference to radio communications. Operation of this equipment in a residential area is likely to cause harmful interference, in which case, the user is required to correct the interference at his own expense.

Industry Canada Information

This Class A digital apparatus complies with Canadian ICES-003.

Ordering Information

The low-power, RoHS-compliant product number is HW-USB-G.

Marking Information

Table 9: Marking Information for Cable Models

| Model Name | Serial Prefix | Description |
|----------------------------|---------------|---|
| DLC9G | UHG | Low-power, RoHS-compliant cable. |
| Legacy Cable Models | | |
| DLC9LP | ULP | Legacy low-power cable. (Not available) |
| DLC9 | UH | Original cable. (Not available) |

Revision History

The following table shows the revision history for this document.

| Date | Version | Revision |
|----------|---------|---|
| 12/10/04 | 1.0 | Initial Xilinx release. |
| 03/14/06 | 1.1 | <ul style="list-style-type: none"> Added Table 3, page 8. Figure 28 and Figure 27, page 13 updated for clarity. Other minor edits and revisions. |
| 04/14/06 | 2.0 | Added Pb-free (RoHS Compliant) Platform Cable USB details to data sheet. |
| 06/14/06 | 2.0.1 | Minor edits for consistent use of the term, Pb-free. |
| 03/02/07 | 3.0 | <ul style="list-style-type: none"> Promote data sheet to Product Specification from Advance Product Specification. Updated cable connection and signal descriptions to include SPI flash support. Added marking information for the DLC9G, legacy DLC9LP, and original DLC9 cables to Table 9, page 19. Updated the "Platform Cable USB Operating Characteristics," page 17 to show the characteristics of the low-power, Pb-free DLC9G cable. Update all cable top labels and pictures with cable top labels with the new "Pb-free" HW-USB-G label. |