

STM32L-DISCOVERY

Introduction

The STM32L-DISCOVERY helps you to discover the STM32L ultralow power features and to develop and share your applications. It is based on an STM32L152RBT6 and includes an ST-LINK/V2 embedded debug tool interface, LCD (24 segments, 4 commons), LEDs, pushbuttons, a linear touch sensor, and four touchkeys.

Figure 1. STM32L-DISCOVERY board

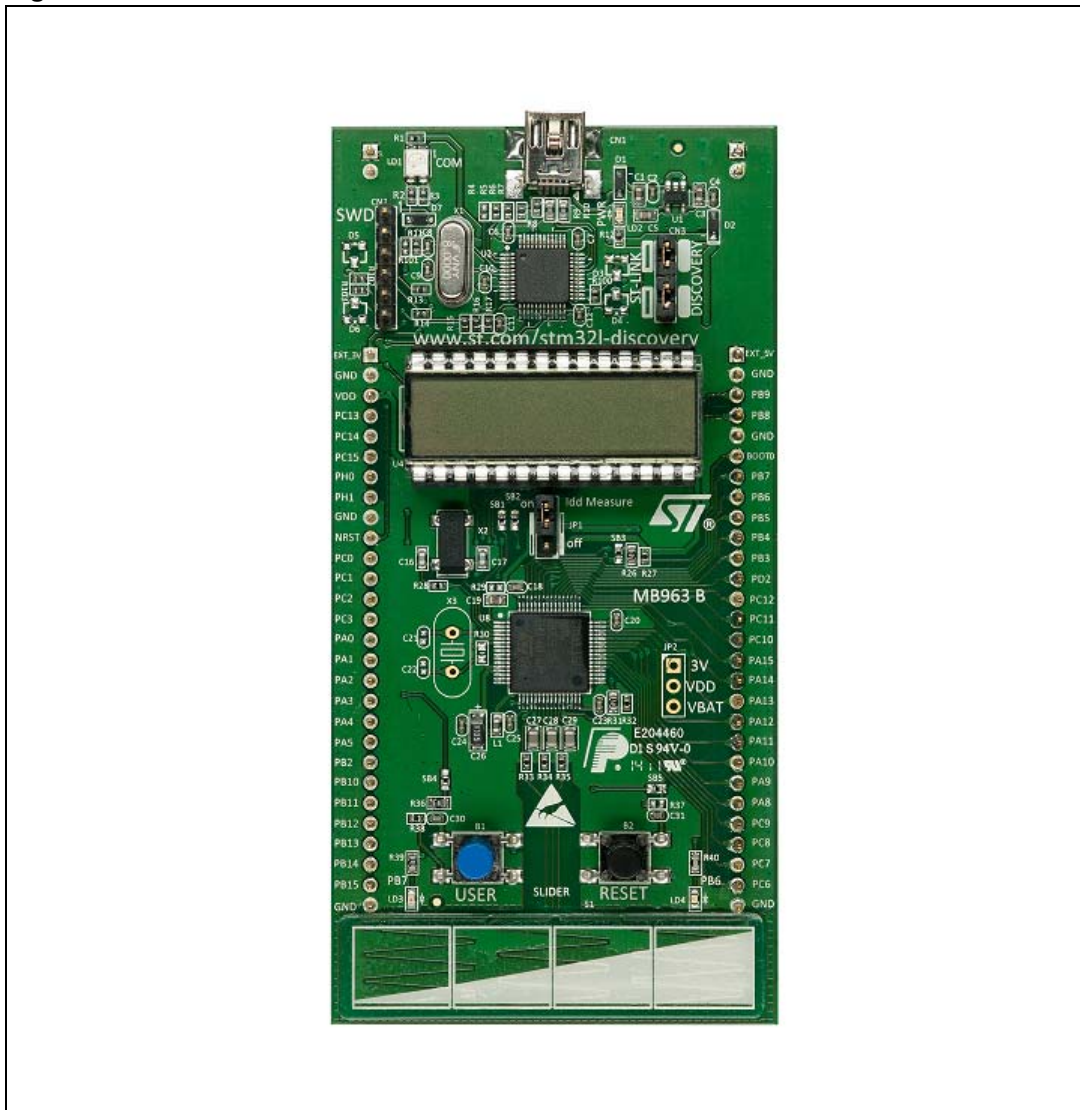

Contents

- 1 Conventions 3**
- 2 Quick start 4**
 - 2.1 Getting started 4
 - 2.2 System requirements 5
 - 2.3 Development toolchain supporting the STM32L-DISCOVERY 5
 - 2.4 Demonstration software 5
 - 2.5 Order code 5
- 3 Features 6**
- 4 Hardware and layout 7**
 - 4.1 STM32L152RBT6 microcontroller 10
 - 4.2 Embedded ST-LINK/V2 12
 - 4.2.1 Using the ST-LINK/V2 to program/debug the STM32L on board 13
 - 4.2.2 Using the ST-LINK/V2 to program/debug an external STM32L application 14
 - 4.3 Power supply and power selection 15
 - 4.4 LEDs 16
 - 4.5 Pushbuttons 16
 - 4.6 Linear touch sensor/touchkeys 16
 - 4.7 Built-in IDD measurement circuit 16
 - 4.7.1 High I_{DD} range mode 17
 - 4.7.2 Low I_{DD} range mode 17
 - 4.7.3 I_{BIAS} current measurement procedure 18
 - 4.8 Solder bridges 19
 - 4.9 LCD (24 segments, 4 commons) 21
- 5 Extension connectors 23**
- 6 Electrical schematics 26**
- 7 Revision history 32**

1 Conventions

[Table 1](#) provides the definition of some conventions used in the present document.

Table 1. ON/OFF conventions

Convention	Definition
Jumper JP1 ON	Jumper placed between pin 2 and 3.
Jumper JP1 OFF	Jumper placed between pin 1 and 2
Solder bridge SBx ON	SBx connections closed by solder
Solder bridge SBx OFF	SBx connections left open

2 Quick start

The STM32L-DISCOVERY is a low-cost and easy-to-use development kit to quickly evaluate and start a development with an STM32L ultralow power microcontroller.

Before installing and using the product, please accept the Evaluation Product License Agreement from www.st.com/stm32l-discovery.

For more information on the STM32L-DISCOVERY and for demonstration software visit www.st.com/stm32l-discovery.

2.1 Getting started







Follow the sequence below to configure the STM32L-DISCOVERY board and launch the DISCOVER application:

1. Check jumper positions on the board: JP1 and CN3 must be ON (Discovery selected) (see [Figure 3 on page 8](#)).
2. Connect the STM32L-DISCOVERY board to a PC with a USB cable to power the board. Red LED LD2 (PWR) and LD1 (COM) are then lit up.
3. Function 1 is executed. Each click on user button B1 changes the executed function as described in [Table 2 on page 4](#).

A 4-LED bar shows the function being performed (1 to 4 bars can be switched ON).

Depending on the function selected, the voltage value, the linear touch sensor position, the touchkey statuses, or the value of the STM32L current consumption is displayed on the LCD.

Table 2. Functions executed when clicking B1 button

Function	LED LD3/4	Bar status	Value displayed on LCD	Main function
1	LD3 and LD4 blink		Measured STM32L V _{DD} voltage	Voltage measurement
2	LD3 ON		Linear touch sensor position from 0 to 100%	Touch sensing
3	LD4 ON		Status of the 4 touchkeys	
4	LD3 and LD4 OFF		STM32L consumption measured in Run mode (4 MHz)	STM32L current consumption measurement
			STM32L consumption measured in Sleep mode (4 MHz)	
5			STM32L consumption measured in Run mode (32 KHz)	
			STM32L consumption measured in low power sleep mode (32 KHz)	
6			STM32L consumption measured in Stop mode, RTC ON	
			STM32L consumption measured in Stop mode, RTC OFF	
7			STM32L consumption measured in Standby mode	

To study or modify the DISCOVER project related to this demonstration, visit www.st.com/stm32l-discovery and follow the tutorial. Discover the STM32L features, download and execute programs proposed in the list of projects. This site also contains examples from which you can develop your own applications.

2.2 System requirements

- Windows PC (2000, XP, Vista, 7)
- USB type A to Mini-B USB cable

2.3 Development toolchain supporting the STM32L-DISCOVERY

- Altium TASKING™ VX-Toolset
- Atollic TrueSTUDIO®
- IAR EWARM
- Keil™ MDK-ARM

2.4 Demonstration software

The demonstration software is preloaded in the board Flash memory. It uses the built-in I_{DD} measurement feature of the STM32L-DISCOVERY to automatically measure and display on the LCD the MCU consumption in Run and low power modes. It also allows to demonstrate touch sensing functionalities such as linear touch sensor or touchkeys.

The latest versions of this demonstration source code and associated documentation can be downloaded from www.st.com/stm32l-discovery.

2.5 Order code

To order the STM32L ultralow power discovery board, use the order code STM32L-DISCOVERY.

3 Features

The STM32L-DISCOVERY offers the following features:

- STM32L152RBT6 microcontroller, featuring 128 KB of Flash memory, 16 KB of RAM, 4 KB of data EPROM, in a 64-pin LQFP package
- On-board ST-LINK/V2 with selection mode switch to use the kit as a standalone ST-LINK/V2 (with SWD connector for programming and debugging)
- Board power supply: through USB bus or from an external 3.3 or 5 V supply voltage
- External application power supply: 3 V and 5 V
- I_{DD} current measurement
- LCD
 - DIP28 package
 - 24 segments, 4 commons
- Four LEDs:
 - LD1 (red/green) indicating USB communication
 - LD2 (red) indicating that 3.3 V power supply is ON
 - Two user LEDs, LD3 (green) and LD4 (blue)
- Two pushbuttons (user and reset)
- One linear touch sensor and four touchkeys
- Extension header for LQFP64 I/Os for quick connection to prototyping board and easy probing

4 Hardware and layout

The STM32L-DISCOVERY is designed around the STM32L152RBT6 microcontroller in a 64-pin LQFP package.

Figure 2 illustrates the connections between the STM32L152RBT6 and its peripherals (ST-LINK/V2, pushbutton, LED, LCD, linear touch sensor, touchkeys, and connectors).

Figure 3 on page 8 and *Figure 4 on page 9* help you to locate these features on the STM32L-DISCOVERY.

Figure 2. Hardware block diagram

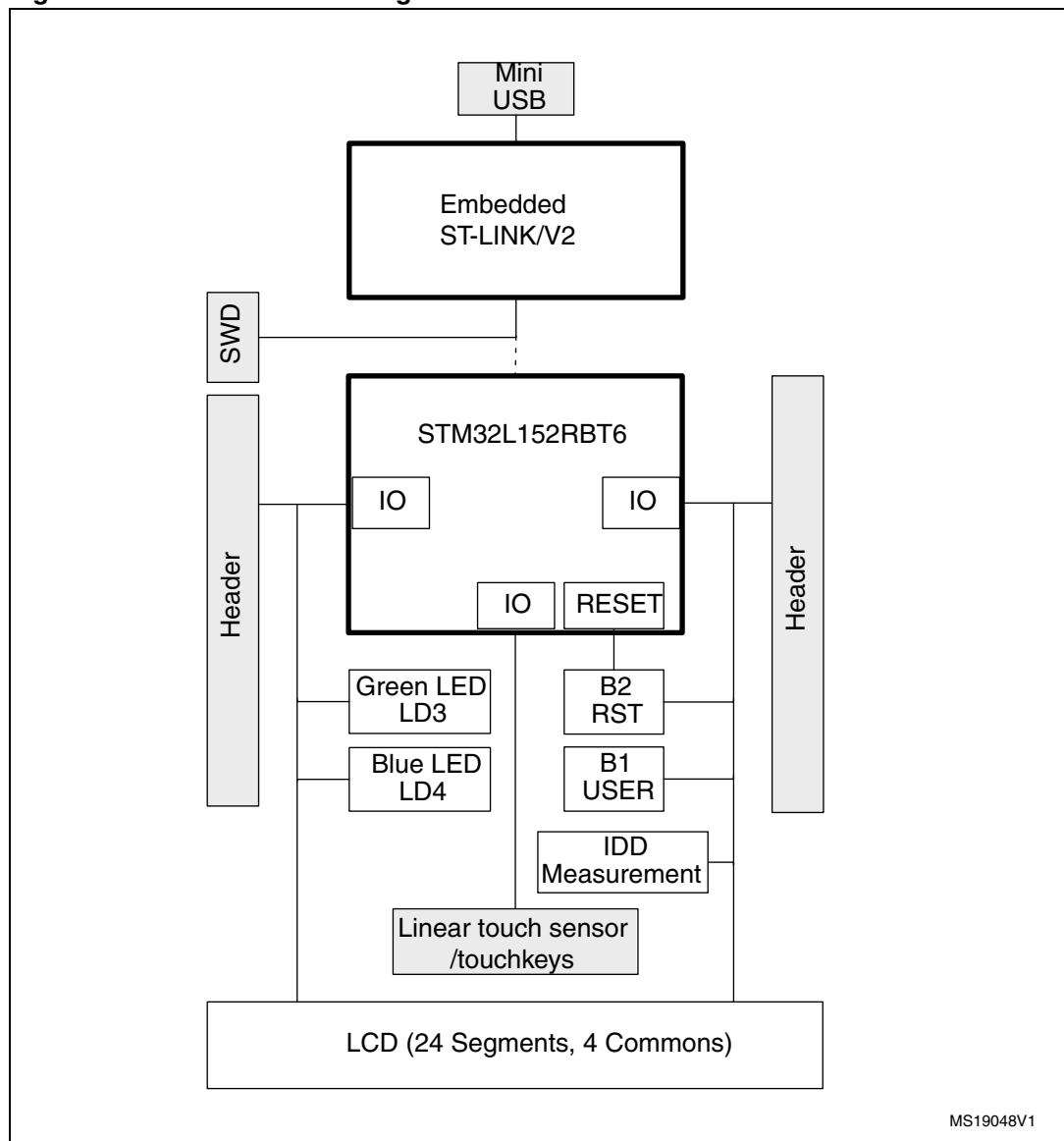
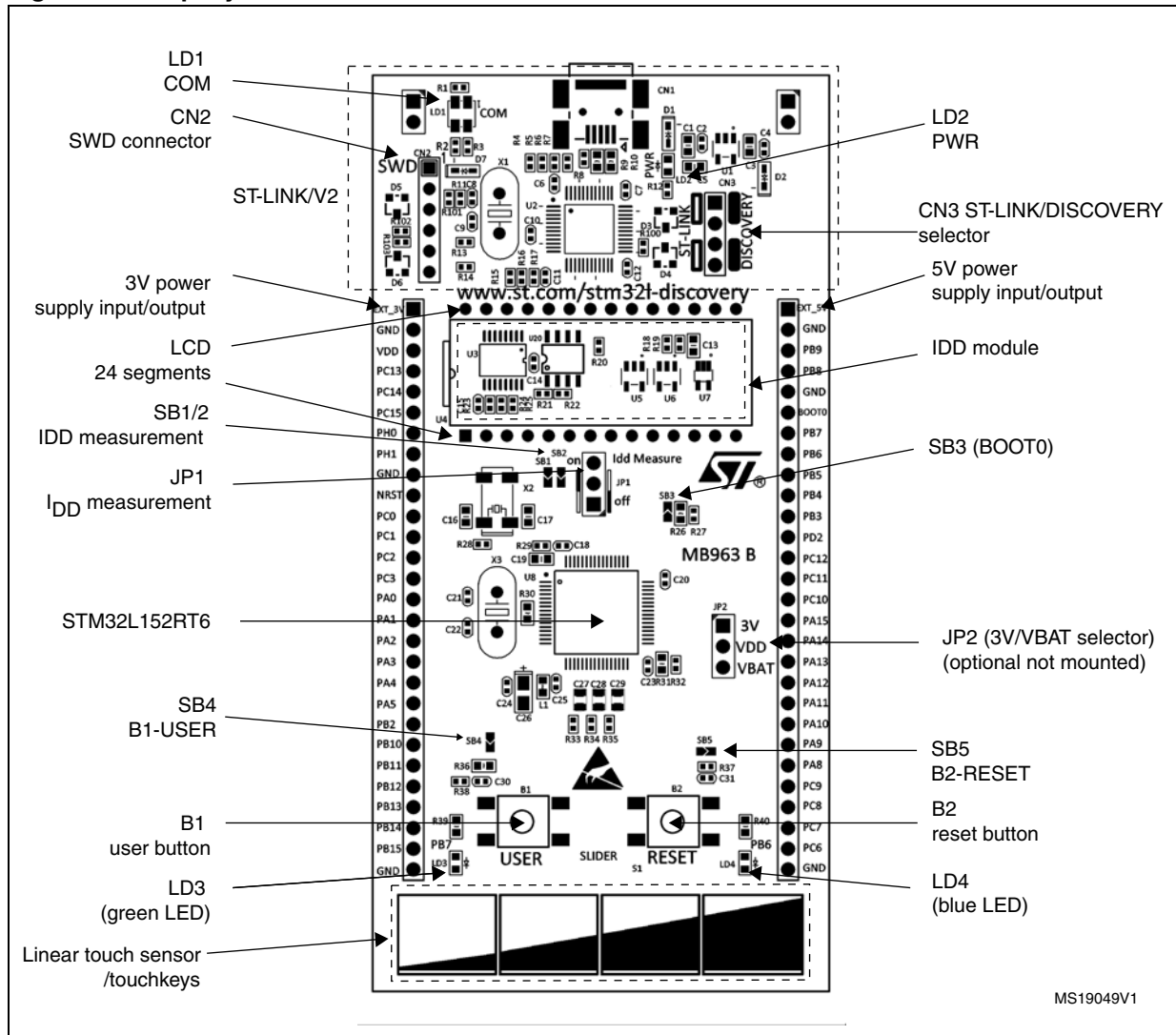

Figure 3. Top layout



MS19049V1

1. Pin 1 of CN1, CN2, P1 and P2 connectors are identified by a square.



Figure 4. Bottom layout

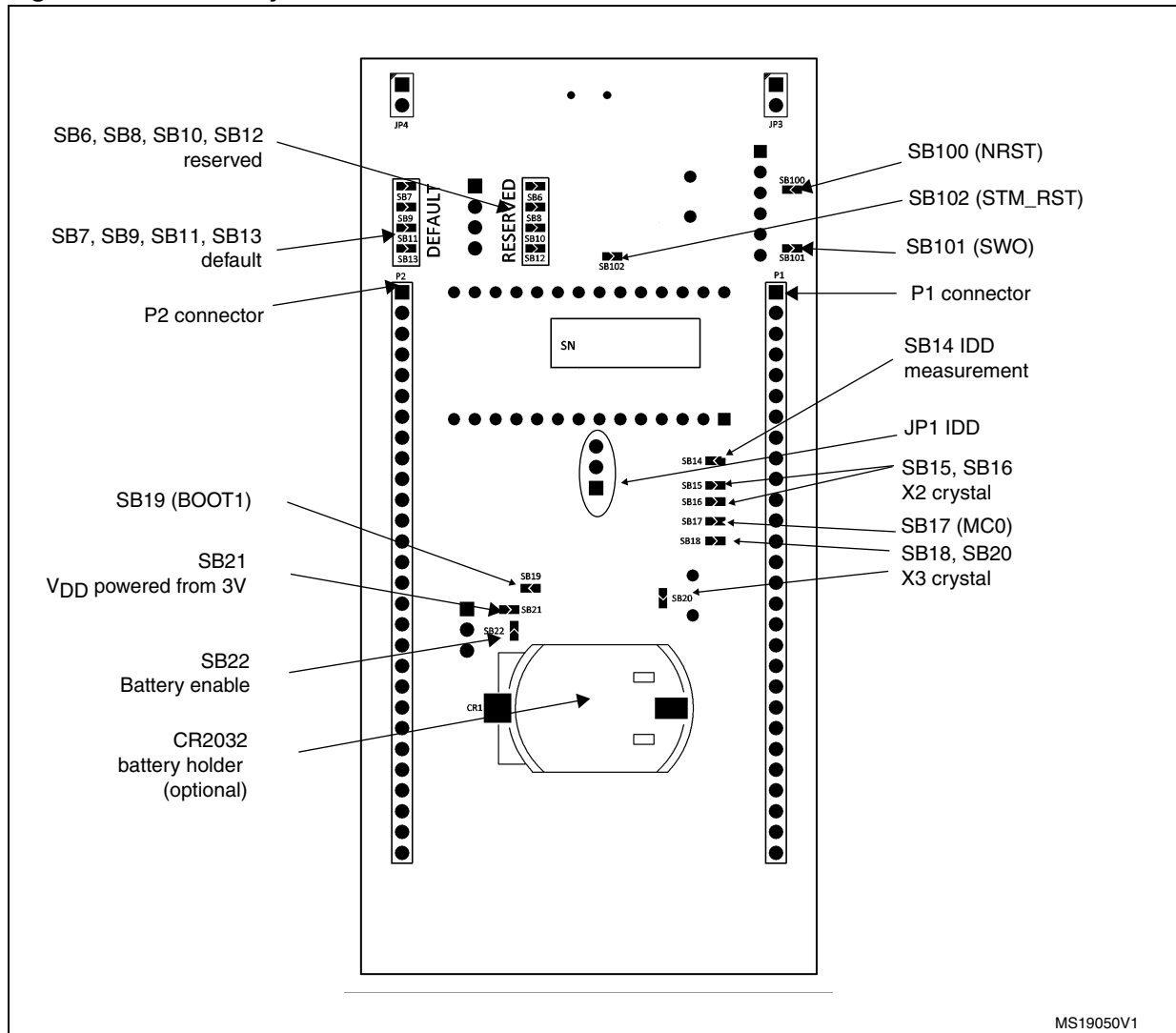

1. Pin 1 of CN1, CN2, P1 and P2 connectors are identified by a square.

4.1 STM32L152RBT6 microcontroller

This 32-bit ultralow power MCU has 128 KB Flash, 16 KB RAM, 4 KB data EEPROM, RTC, LCD, timers, USART, I2C, SPI, ADC, DAC and comparators.

Figure 5. STM32L152RBT6 package

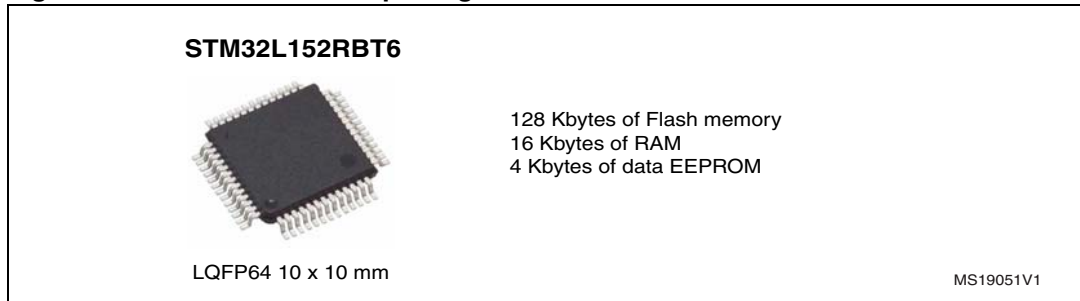

This device provides the following benefits:

- **Ultralow power proprietary 130 nm technology:**
Speed and power consumption independent of MCU power supply, and ultralow leakage
- **Ultralow power design (clock gating, low-power Flash with power-off capability):**
Reduced overall Run and Wait mode current consumption by turning off clocks of unused peripherals or Flash
- **Sub 1 μ A hardware RTC and AWU system unit:**
Ultralow power modes for applications requesting regular wake up
- **Up to 6 low power modes:**
Suitable for many applications from complete switch off to continuous monitoring at ultralow frequency
- **Advanced and flexible clock system (multiple internal and external clock sources)**
Switch and adjust frequency and clock sources on the fly depending on application needs
- **Direct memory access on board (up to 12 DMA channels):**
Autonomy for peripherals, independent from core; can switch off Flash memory and CPU (large current consumption contributors) while keeping peripherals active
- **Ultralow power and ultrasafe features (POR, PDR, BOR, PVD) allowing integrated application safety and security**
- **Unique identifier to enhance user data confidentiality/reliability**
- **Ultrafast wakeup from lowest consumption low-power mode allowing fast switching from static and dynamic power modes**
- **Analog functional down to 1.8 V, and programming down to 1.65 V**
- **Full functionality over the complete V_{DD} range**

For more information, refer to the STM32L152RBT6 datasheet on the ST website.

Figure 6. STM32L152RBT6 block diagram

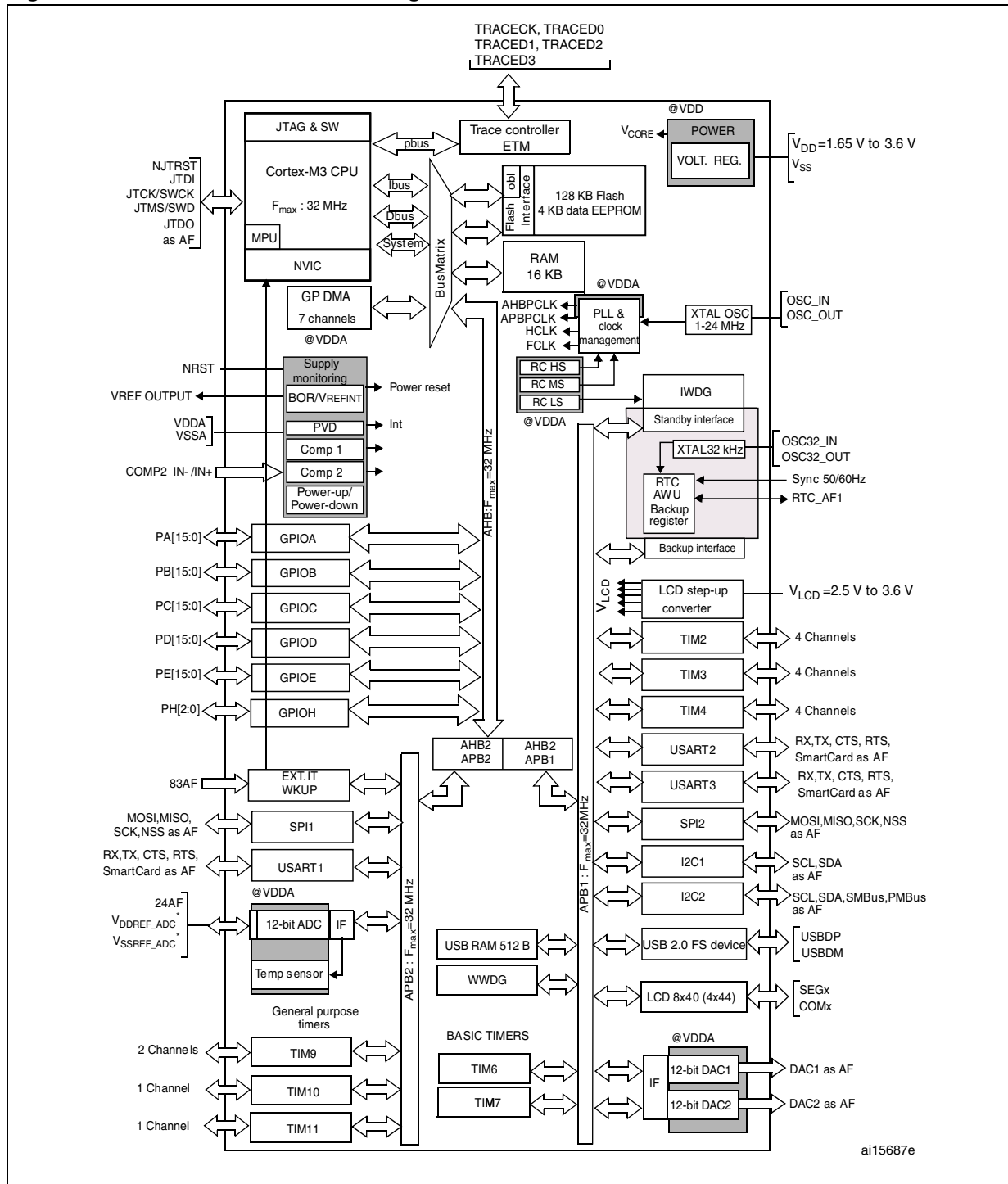

ai15687e

4.2 Embedded ST-LINK/V2

The ST-LINK/V2 programming and debugging tool is integrated on the STM32L-DISCOVERY. The embedded ST-LINK/V2 can be used in 2 different ways according to the jumper states (see [Table 3 on page 12](#)):

- Program/debug the MCU on board,
- Program/debug an MCU in an external application board using a cable connected to SWD connector CN2.

The embedded ST-LINK/V2 supports only SWD for STM32 devices. For information about debugging and programming features refer to user manual UM1075 which describes in detail all the ST-LINK/V2 features.

Figure 7. Typical configuration

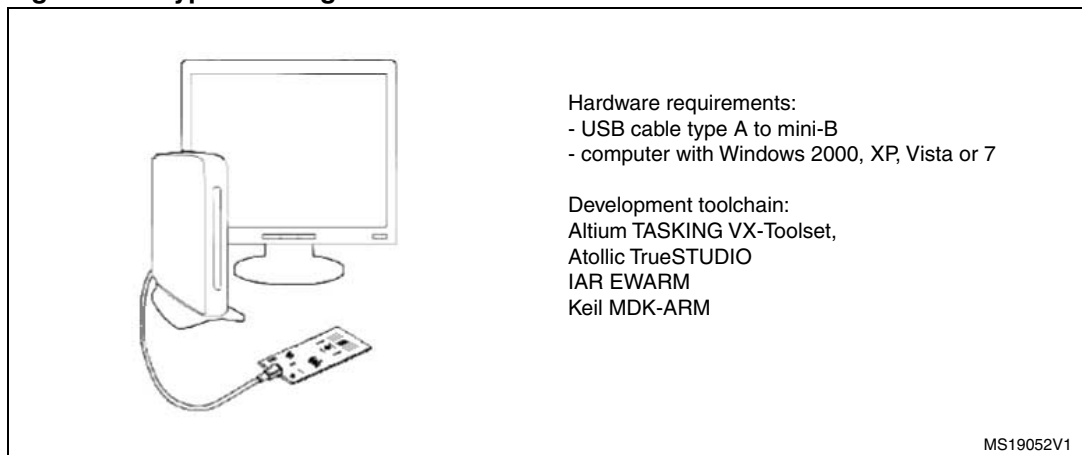

Table 3. Jumper states

Jumper state	Description
Both CN3 jumpers ON	ST-LINK/V2 functions enabled for on board programming (default)
Both CN3 jumpers OFF	ST-LINK/V2 functions enabled for external application through CN2 connector (SWD supported).

4.2.1 Using the ST-LINK/V2 to program/debug the STM32L on board

To program the STM32L on board, simply plug in the two jumpers on CN3, as shown in [Figure 8](#) in red, but do not use the CN2 connector as that could disturb communication with the STM32L152RBT6 of the STM32L-DISCOVERY.

Figure 8. STM32L-DISCOVERY connections image

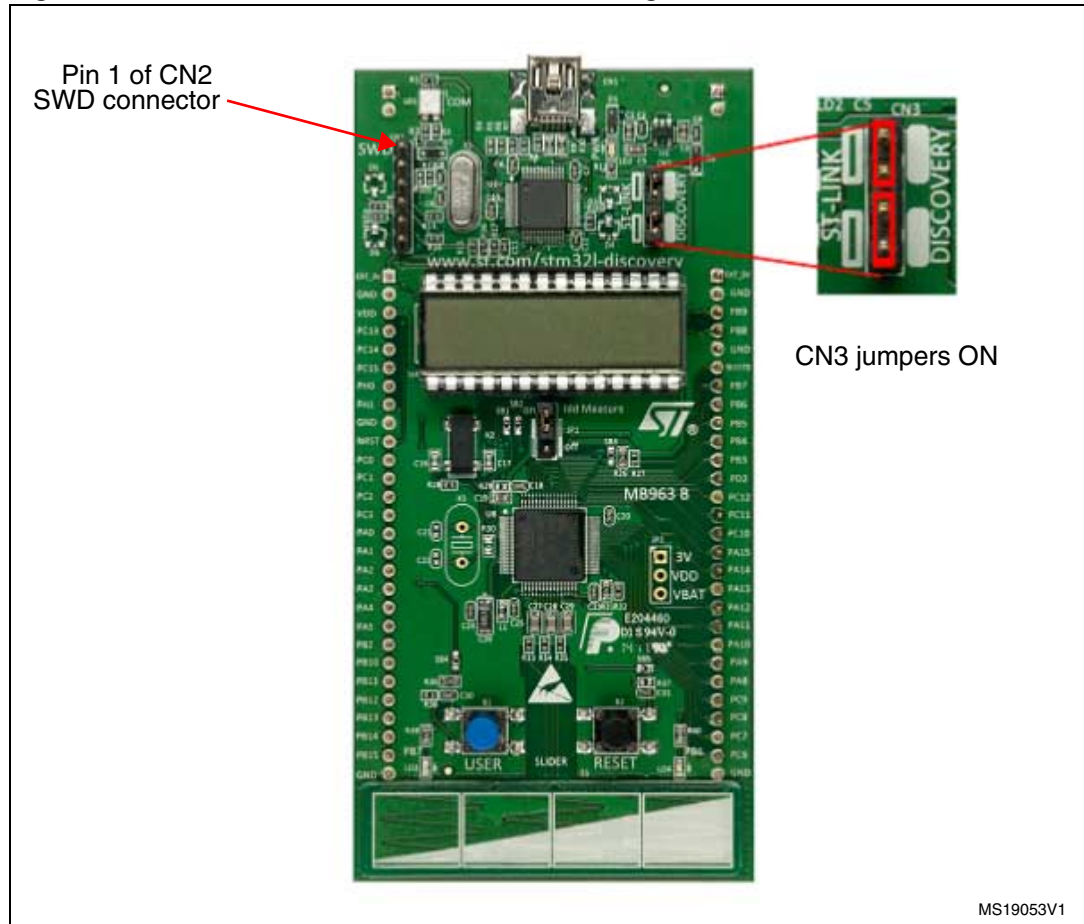

4.2.2 Using the ST-LINK/V2 to program/debug an external STM32L application

It is very easy to use the ST-LINK/V2 to program the STM32L on an external application. Simply remove the 2 jumpers from CN3 as shown in [Figure 9](#), and connect your application to the CN2 debug connector according to [Table 4](#).

Note: SB100 must be OFF if you use CN2 pin 5 in your external application.

Table 4. Debug connector CN2 (SWD)

Pin	CN2	Designation
1	VDD_TARGET	VDD from application
2	SWCLK	SWD clock
3	GND	Ground
4	SWDIO	SWD data input/output
5	NRST	RESET of target MCU
6	SWO	Reserved

Figure 9. ST-Link connections image

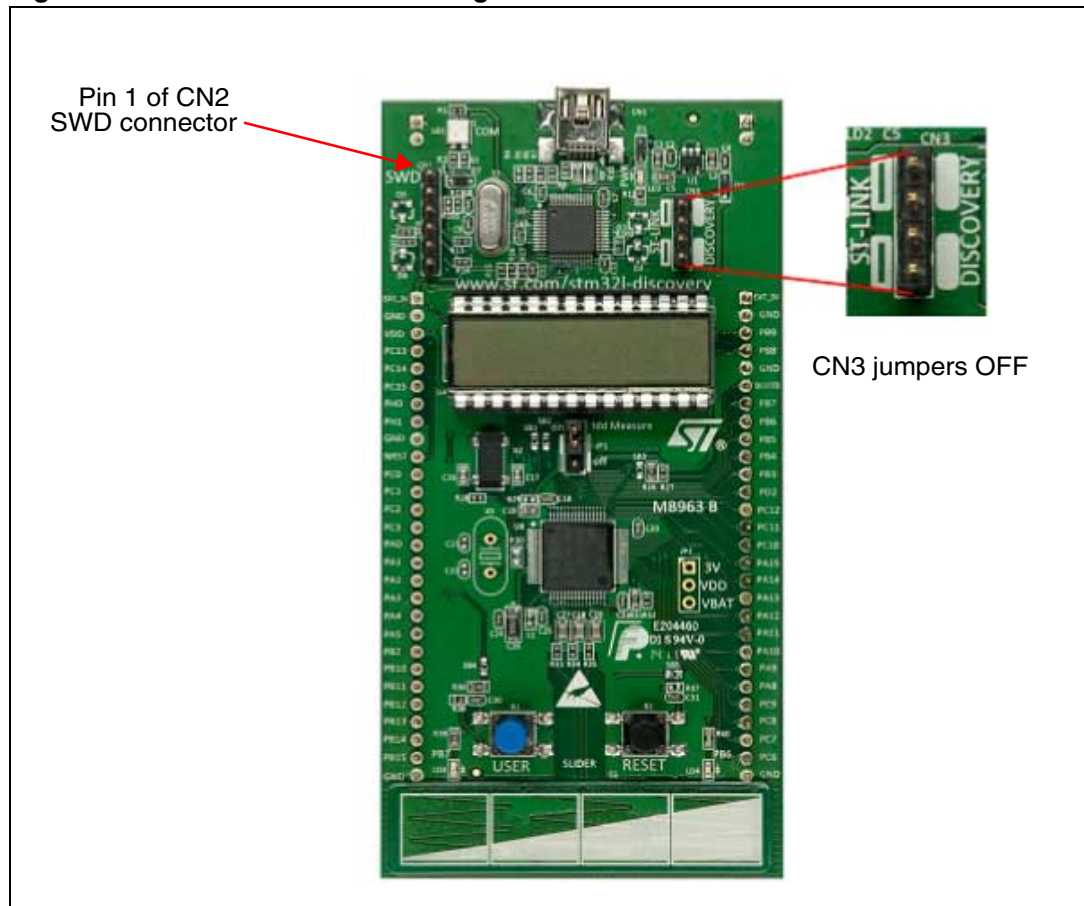

4.3 Power supply and power selection

The power supply is provided either by the host PC through the USB cable, or by an external 5 V or 3.3 V power supply.

The D1 and D2 protection diodes allow the EXT_5V and EXT_3V pins to be used independently as input or output power supplies (see [Figure 3 on page 8](#)):

- EXT_5V and EXT_3V can be used as output power supplies when the application board is connected to pin headers P1 and P2. In this case, the EXT_5V and EXT_3V pins deliver only a 5 V or 3 V power supply and the power consumption must be lower than 100 mA.
- EXT_5V and EXT_3V can also be used as input power supplies e.g. when the USB connector is not connected to the PC.

Battery powered (optional)

In addition, the STM32L-DISCOVERY board has been designed to run from a CR2032 standalone battery (no connection with USB or other power supply is required).

By default, no battery holder is mounted on the board and SB21 and SB22 are configured in their default state (see [Table 5: Solder bridges on page 19](#)).

Follow the procedure below to power the STM32L-DISCOVERY from the battery:

1. Solder a B7410AP2L battery holder from LOTES on CR1.
2. Configure SB100 OFF.
3. Remove both jumpers from CN3 (see [Figure 9](#))
4. Select the battery as power supply. Two solutions are possible:
 - a) Solder bridge
Configure SB21 OFF, and SB22 ON. No header is required on JP2.
 - b) Jumper
Configure SB21 and SB22 OFF.
Solder a header on JP2, identical to JP1 on the top side, and set a jumper between VDD and VBAT to power the STM32L MCU.

Note: In this configuration, it is possible to power the STM32L from the board 3 V supply voltage by setting a jumper between VDD and 3V.

5. Plug the CR2032 battery into CR1 holder. You can now start running the demonstration.

Warning: Wrong solder bridge configuration can damage the board components.

4.4 LEDs

- LD1 COM: LD1 default status is red. LD1 turns to green to indicate that communications are in progress between the PC and the ST-LINK/V2.
- LD2 PWR: red LED indicates that the board is powered.
- User LD3: green LED is a user LED connected to the I/O PB7 of the STM32L152RBT6.
- User LD4: blue LED is a user LED connected to the I/O PB6 of the STM32L152RBT6.

4.5 Pushbuttons

- B1 USER: User pushbutton connected to the I/O PA0 of the STM32L152RBT6.
- B2 RESET: Pushbutton is used to RESET the STM32L152RBT6.

4.6 Linear touch sensor/touchkeys

To demonstrate touch sensing capabilities, the STM32L-DISCOVERY includes a linear touch sensor which can be used either as a 3-position linear touch sensor or as 4 touchkeys. Both functionalities are illustrated in the demonstration software (see [Table 2: Functions executed when clicking B1 button on page 4](#)).

3 pairs of I/O ports are assigned to the linear touch sensor/touchkeys. Each pair must belong to the same analog switch group:

- PA6, PA7 (group 2)
- PC4, PC5 (group 9)
- PB0, PB1 (group 3)

To minimize the noise, these pairs are dedicated to the linear touch sensor and the touchkeys and are not connected to external headers.

To design a touch sensing application, refer to the following documentation and firmware:

- For details concerning I/O ports, refer to the STM32L152RBT6 datasheet.
- For information on software development, see DISCOVER application software on <http://www.st.com/stm32l-discovery>.
- For more detail concerning touch sensing application design and layout, refer to AN2869 -Guidelines for designing touch sensing applications.
- STM32 touch sensing library available from <http://www.st.com/stm32l-discovery>.

4.7 Built-in IDD measurement circuit

The STM32L-DISCOVERY built-in I_{DD} measurement circuit allows the consumption of the STM32L152RBT6 to be measured and displayed on the LCD Glass while the MCU is in Run or low power modes.

- JP1 ON: STM32L152RBT6 is powered through the I_{DD} measurement circuit (default).
- JP1 OFF: STM32L152RBT6 is directly powered, I_{DD} measurement circuit is bypassed.

Note: When jumper JP1 is removed the current consumption of the STM32L152RBT6 can be measured by connecting an ammeter between jumper pin 1 and pin 2 of JP1.

For I_{DD} measurement to be performed by the MCU itself, the circuit below is implemented on the STM32L-DISCOVERY. Solder bridges SB1, SB2 and SB14 must be closed and JP1 must be ON. The **low I_{DD} range** procedure (see [Section 4.7.2](#)) is recommended when the MCU is in low power mode and the I_{DD} current does not exceed 60 μ A. When the MCU operates in Run mode and can sink up to 30 mA, use the **high I_{DD} range** procedure (see [Section 4.7.1](#)).

Figure 10. STM32L-DISCOVERY I_{DD} measurement circuit

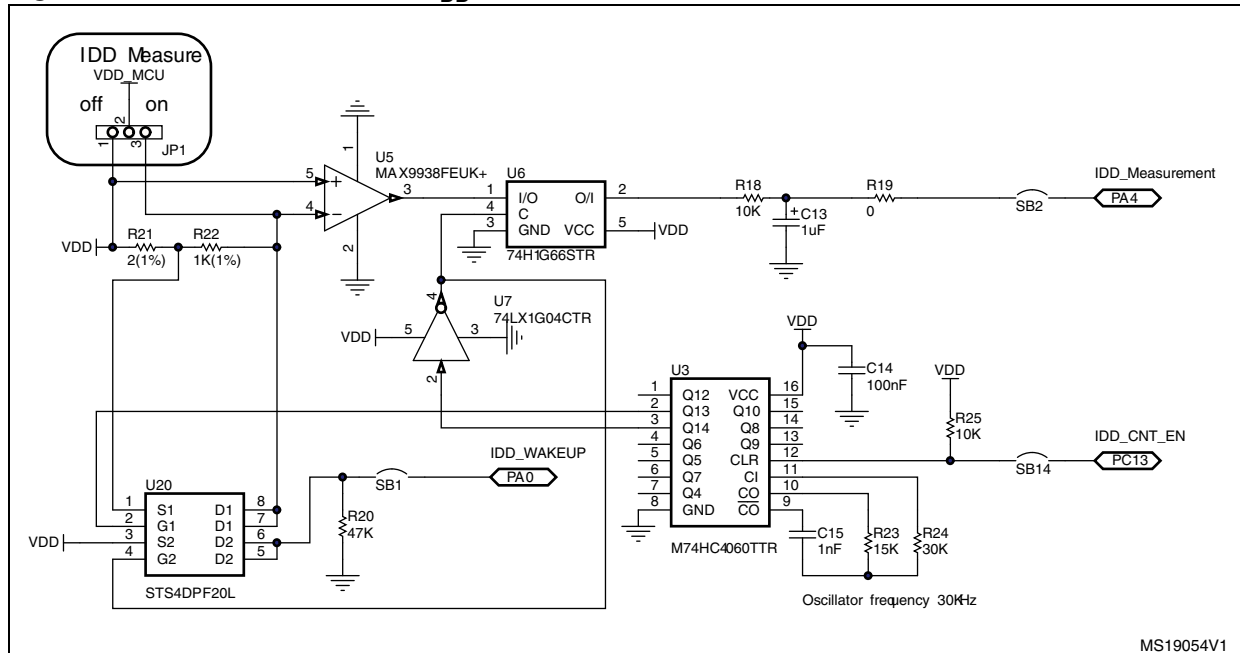

4.7.1 High I_{DD} range mode

In high I_{DD} range mode, the I_{DD} current is measured using the operational amplifier MAX9938FEUK+ (U5) connected to the 2 Ω shunt resistor (R21). In this case IDD_CNT_EN remains high during measurement, so R22 remains in short-circuit during the measurement because FET transistor 1 of U20 remains ON permanently.

4.7.2 Low I_{DD} range mode

In low I_{DD} range mode, the operational amplifier MAX9938FEUK+ (U5) is connected to the 1 K Ω shunt resistor (R22), controlled by FET transistor 1 of U20. In this case the counter 74HC4060 (U3) enabled by IDD_CNT_EN manages the measurement timing according to [Figure 11 on page 18](#).

Low I_{DD} range measurement principle

The principle used to measure the consumption current when the STM32L152RBT6 is in low I_{DD} range mode is as follows:

1. Configure ADC to measure voltage on the IDD_Measurement pin.
2. Configure PA0 to serve as wakeup pin.
3. Enter low I_{DD} range mode after setting IDD_CNT_EN (PC13) signal low.
4. IDD_WAKEUP rising edge wakes up the MCU after around 300 ms.
5. Start ADC conversion as soon as possible after wakeup in order to measure the voltage corresponding to Low power mode on capacitor C13.
6. Reset the counter by programming IDD_CNT_EN high (in less than 150 ms after the wakeup) to avoid the R22 1 KΩ resistor being connected later in Run mode.

The measurement timing is given in *Figure 11*. In low I_{DD} range mode, the 1 KΩ resistor is connected when FET transistor 1 of U20 goes OFF after entering low I_{DD} range mode. The Q13 output of the counter allows connecting the 1 KΩ resistor when the current I_{DD} becomes very low.

Figure 11 shows how the counter and FET transistor 1 of U20 ensure that, 150 ms after IDD_CNT_EN falling edge, the shunt resistor R22 is connected between VDD_MCU and the power supply to reduce the measurement range to 60 μA for the full scale. Then after another 150 ms required for current stabilization, R22 is shorted, the I_{DD} measurement is stored in C13, and the MCU is woken up. After wakeup the MCU can measure the I_{DD} current corresponding to the low power mode stored in C13.

Figure 11. STM32L-DISCOVERY low I_{DD} range measurement timing diagram

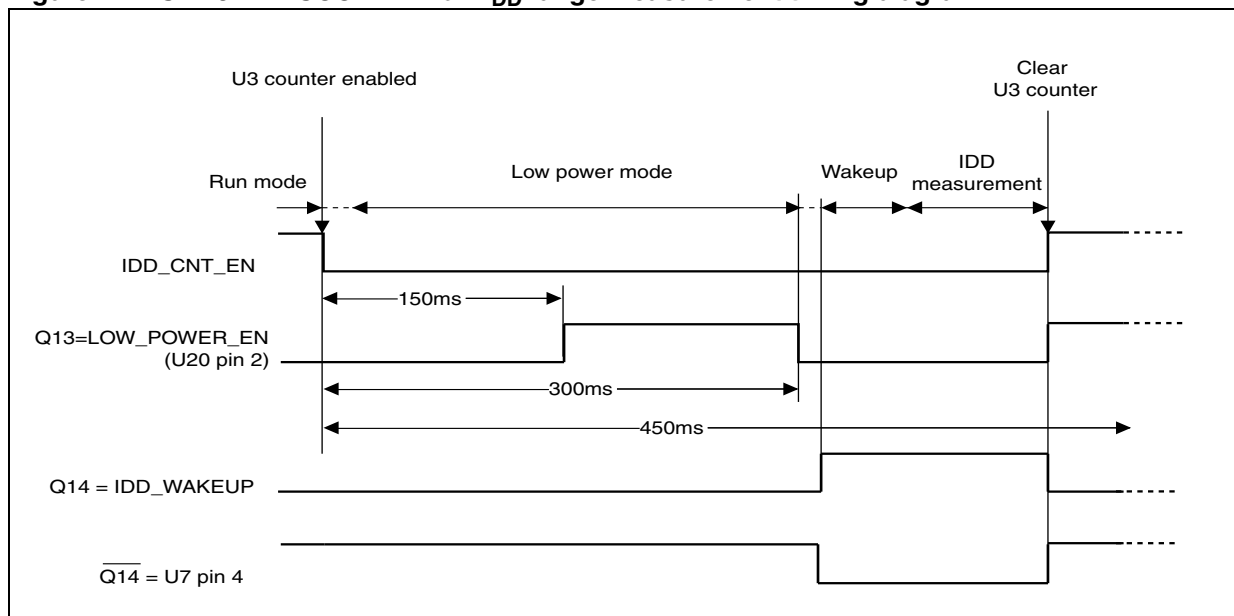

4.7.3 I_{BIAS} current measurement procedure

In Low I_{DD} range mode, the bias current of the operational amplifier input (U5 pin 4) is not negligible compared to I_{DD} current (typical I_{BIAS} is ~240 nA). To obtain a reliable STM32L152RBT6 I_{DD} measurement, it is mandatory to subtract the bias current from the low I_{DD} current value since this current is not sinked by the MCU. I_{BIAS} is measured during production test and stored in the MCU data EEPROM. The DISCOVER demonstration software, uses this value to display the correct I_{DD}.

The procedure for I_{BIAS} measurement implemented in the demonstration software is:

1. Power off the board (disconnect the USB cable).
2. Set JP1 OFF.
3. Push down B1 (USER button), power on the board from the USB.
4. Wait at least 1 second before releasing B1, the LCD displays the I_{BIAS} measurement.
5. Power off the board (disconnect the USB cable).
6. Set JP1 ON. The I_{BIAS} value is stored in data EEPROM. The bias current is then subtracted from the I_{DD} measured in I_{DD} range mode.

4.8 Solder bridges

Table 5. Solder bridges

Bridge	State ⁽¹⁾	Description
SB18,20 (X3 crystal) ⁽²⁾	ON	PH0, PH1 are connected to P1 (X3, C21, C22, R30 must not be fitted).
	OFF	X3, C21, C22 and R30 provide a clock as shown in Section 6: Electrical schematics . PH0, PH1 are disconnected from P1.
SB7,9,11,13 (DEFAULT)	ON	Reserved, do not modify.
SB6,8,10,12 (RESERVED)	OFF	Reserved, do not modify.
SB1,2,14 (IDD_Measurement)	ON	PA0, PA4, PC13 are used by the I_{DD} measurement. JP1 ON.
	OFF	PA0, PA4, PC13 are available and IDD module cannot be used JP1 OFF.
SB15,16 (X2 crystal)	OFF	X2, C16, C17 and R28 deliver a 32 KHz clock. PC14, PC15 are not connected to P1.
	ON	PC14, PC15 are only connected to P1. Do not remove X2, C16, C17, R28.
SB5 (B2-RESET)	ON	B2 Pushbutton is connected to the NRST pin of the STM32L152RBT6 MCU.
	OFF	B2 Pushbutton is not connected the NRST pin of the STM32L152RBT6 MCU.
SB4 (B1-USER)	ON	B1 Pushbutton is connected to PA0.
	OFF	B1 Pushbutton is not connected to PA0.
SB21 (VDD powered from 3 V)	ON	V_{DD} is powered from 3 V, SB22 must be OFF.
	OFF	V_{DD} is not powered from 3 V, SB22 must be ON.
SB22 (Battery enable)	OFF	V_{DD} is not powered by the CR2032 battery, SB21 must be ON.
	ON	V_{DD} is powered by the CR2032 battery, SB21 must be OFF.

Table 5. Solder bridges (continued)

Bridge	State ⁽¹⁾	Description
SB100 (NRST)	ON	The NRST signal of the CN2 connector is connected to the NRST pin of the STM32L152RBT6 MCU.
	OFF	The NRST signal of the CN2 connector is not connected to the NRST pin of the STM32L152RBT6 MCU.
SB101 (SWO)	ON	The SWO signal of the CN2 connector is connected to PB3.
	OFF	The SWO signal is not connected.
SB102 (STM_RST)	OFF	No incidence on STM32F103C8T6 NRST signal.
	ON	STM32F103C8T6 NRST signal is connected to GND.
SB3 (BOOT0)	ON	The BOOT0 signal of the STM32L152RBT6 MCU is held low through a 510 Ω pull-down resistor.
	OFF	The BOOT0 signal of the STM32L152RBT6 MCU is held high through a 10 K Ω pull-up resistor.
SB19 (BOOT1)	OFF	The BOOT1 signal of the STM32L152RBT6 MCU is held high through a 10 K Ω pull-up resistor.
	ON	The BOOT1 signal of the STM32L152RBT6 MCU is held low through a 510 Ω pull-down resistor.
SB17 (MCO) ⁽²⁾	OFF	STM32F103C8T6 MCO clock signal is not used.
	ON	STM32F103C8T6 MCO clock signal is connected to OSC_IN of the STM32L152RBT6 MCU.

1. Default SBx state is shown in bold.

2. SB17 and SB20 are OFF to allow the user to choose between MCO and X3 crystal for clock source.

4.9 LCD (24 segments, 4 commons)

This LCD allows the STM32L152RBT6 to display any information on six 14-segment digits and 4 bars, using all COMs. (See the LCD segment mapping in [Figure 16](#) and pin connections in [Table 6](#).)

Note: This LCD also supports six 8-segment digits by only using COM0 and COM1. This configuration allows COM2 and COM3 to be used as I/O ports. In this case the 2 LCD pins must not be plugged into the LCD socket. To proceed with this configuration, remove the LCD carefully, slightly open the COM2 and COM3 pins (pin 13 and pin 14) of the LCD, then replug it in the socket.

Characteristics overview:

- 24 segments and 4 commons
- Drive method: multiplexed 1/4 duty, 1/3 bias
- Operating voltage: 3 V
- Operating temperature: 0 to 50°C
- Connector: 28-pin DIL 2.54 mm pitch

Note: When the LCD is plugged, all I/O ports listed in [Table 6](#) are unavailable. To use one of these as I/O, you must remove the LCD.

Figure 12. LCD segment mapping

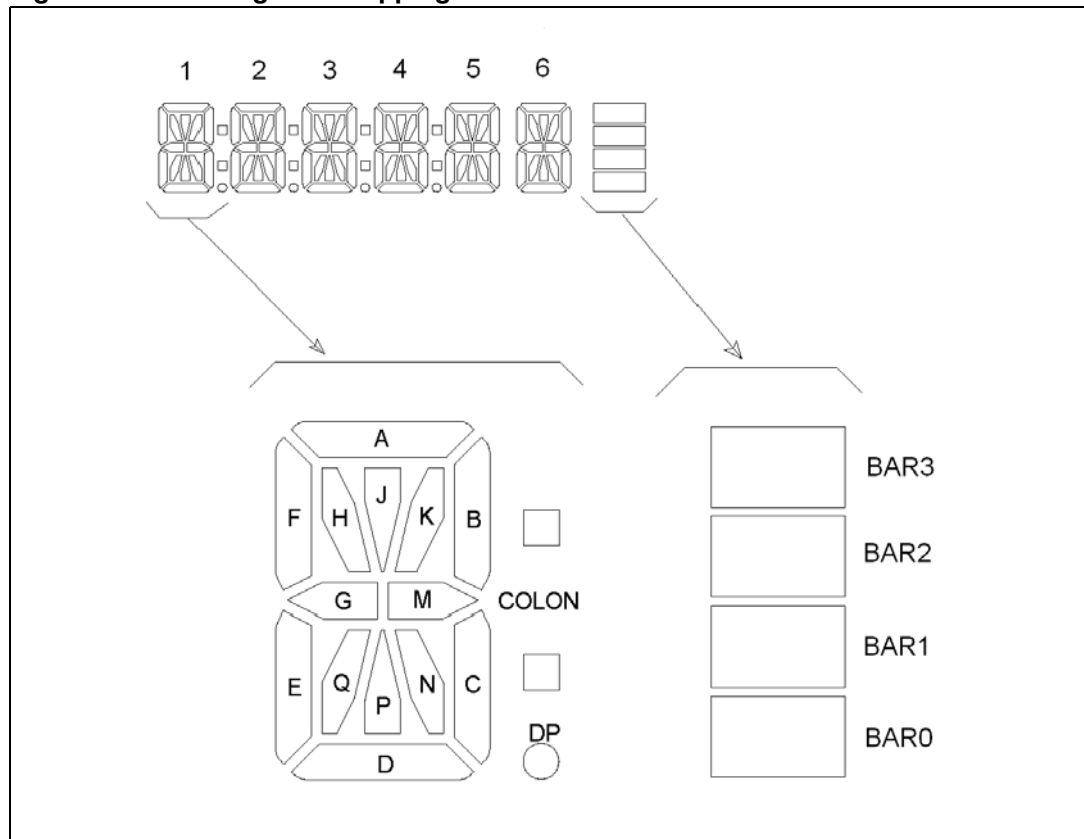

Table 6. LCD connections

STM32L152	LCD					
Name	Pin	COM3	COM2	COM1	COM0	Name
PA1	1	1N	1P	1D	1E	LCDSEG0
PA2	2	1DP	1COLON	1C	1M	LCDSEG1
PA3	3	2N	2P	2D	2E	LCDSEG2
PB3	4	2DP	2COLON	2C	2M	LCDSEG3
PB4	5	3N	3P	3D	3E	LCDSEG4
PB5	6	3DP	3COLON	3C	3M	LCDSEG5
PB10	7	4N	4P	4D	4E	LCDSEG6
PB11	8	4DP	4COLON	4C	4M	LCDSEG7
PB12	9	5N	5P	5D	5E	LCDSEG8
PB13	10	BAR2	BAR3	5C	5M	LCDSEG9
PB14	11	6N	6P	6D	6E	LCDSEG10
PB15	12	BAR0	BAR1	6C	6M	LCDSEG11
PB9	13	COM3				LCDCOM3
PA10	14		COM2			LCDCOM2
PA9	15			COM1		LCDCOM1
PA8	16				COM0	LCDCOM0
PA15	17	6J	6K	6A	6B	LCDSEG12
PB8	18	6H	6Q	6F	6G	LCDSEG13
PC0	19	5J	5K	5A	5B	LCDSEG14
PC1	20	5H	5Q	5F	5G	LCDSEG15
PC2	21	4J	4K	4A	4B	LCDSEG16
PC3	22	4H	4Q	4F	4G	LCDSEG17
PC6	23	3J	3K	3A	3B	LCDSEG18
PC7	24	3H	3Q	3F	3G	LCDSEG19
PC8	25	2J	2K	2A	2B	LCDSEG20
PC9	26	2H	2Q	2F	2G	LCDSEG21
PC10	27	1J	1K	1A	1B	LCDSEG22
PC11	28	1H	1Q	1F	1G	LCDSEG23

5 Extension connectors

The male headers P1 and P2 can connect the STM32L-DISCOVERY to a standard prototyping/wrapping board. STM32L152RBT6 GPIOs are available on these connectors. P1 and P2 can also be probed by an oscilloscope, logical analyzer or voltmeter.

Table 7. MCU pin description versus board function

MCU pin			Board function										
Main function	Alternate functions	LQFP 64 pin num.	LCD glass	Linear Touch Sensor	Push button	I _{DD}	LED	SWD	OSC	Free I/O	Power supply	P1	P2
-	-	-									EXT_3V	1	
-	-										EXT_5V		1
BOOT0	-	60											6
NRST	-	7						NRST				10	
PA0	WKUP1/USART2_CTS/ ADC_IN0/TIM2_CH1_ETR/ COMP1_INP	14			PA0	WAKE UP						15	
PA1	USART2_RTS/ADC_IN1/ TIM2_CH2/LCD_SEG0/ COMP1_INP	15	SEG0									16	
PA2	USART2_TX/ADC_IN2/ TIM2_CH3/TIM9_CH1/ LCD_SEG1/COMP1_INP	16	SEG1									17	
PA3	USART2_RX/ADC_IN3/ TIM2_CH4/TIM9_CH2/ LCD_SEG2/COMP1_INP	17	SEG2									18	
PA4	SPI1_NSS/USART2_CK/ ADC_IN4/DAC_OUT1/ COMP1_INP	20				Measurement						19	
PA5	SPI1_SCK/ADC_IN5/ DAC_OUT2/ TIM2_CH1_ETR/COMP1_INP	21								X		20	
PA6	SPI1_MISO/ADC_IN6/ TIM3_CH1/TIM1_BKIN/ LCD_SEG3/TIM10_CH1/ COMP1_INP	22		PA6									
PA7	SPI1_MOSI/ADC_IN7/ TIM3_CH2/TIM1_CH1N/ LCD_SEG4/TIM11_CH1/ COMP1_INP	23		PA7									
PA8	USART1_CK/MCO/ LCD_COM0	41	COM0										23
PA9	USART1_TX/LCD_COM1	42	COM1										22
PA10	USART1_RX/LCD_COM2	43	COM2										21
PA11	USART1_CTS/USBDM/ SPI1_MISO	44								X			20
PA12	USART1_RTS/USBDP/ SPI1_MOSI	45								X			19
JTMS/ SWDIO	PA13	46						SWD IO					18

Table 7. MCU pin description versus board function (continued)

MCU pin			Board function										
Main function	Alternate functions	LQFP 64 pin num.	LCD glass	Linear Touch Sensor	Push button	I _{DD}	LED	SWD	OSC	Free I/O	Power supply	P1	P2
JTCK/ SWCLK	PA14	49						SW CLK					17
JTDI	TIM2_CH1_ETR/PA15/ SPI1_NSS/LCD_SEG17	50	SEG12										16
PB0	ADC_IN8/TIM3_CH3/ LCD_SEG5/COMP1_INP/ VREF_OUT	26		PB0									
PB1	ADC_IN9/TIM3_CH4/ LCD_SEG6/COMP1_INP/ VREF_OUT	27		PB1									
PB2/BOOT1	-	28										21	
JTDO	TIM2_CH2/PB3/TRACES WO/SPI1_SCK/COMP2_I NM/LCD_SEG7	55	SEG3					SWO					11
JNTRST	TIM3_CH1/PB4/SPI1_MIS O/COMP2_INP/LCD_SEG 8	56	SEG4										10
PB5	I2C1_SMBAI/TIM3_CH2/ SPI1_MOSI/COMP2_INP/ LCD_SEG9	57	SEG5										9
PB6	I2C1_SCL/TIM4_CH1/ USART1_TX/LCD_SEG8	58					Blue						8
PB7	I2C1_SDA/TIM4_CH2/ USART1_RX/PVD_IN	59					Green						7
PB8	TIM4_CH3/I2C1_SCL/ LCD_SEG16/TIM10_CH1	61	SEG13										4
PB9	TIM4_CH4/I2C1_SDA/ LCD_COM3/TIM11_CH1	62	COM3										3
PB10	I2C2_SCL/USART3_TX/ TIM2_CH3/LCD_SEG10	29	SEG6									22	
PB11	I2C2_SDA/USART3_RX/ TIM2_CH4/LCD_SEG11	30	SEG7									23	
PB12	SPI2_NSS/I2C2_SMBIA/ USART3_CK/LCD_SEG1 2/ADC_IN18/COMP1_INP /TIM10_CH1	33	SEG8									24	
PB13	SPI2_SCK/USART3_CTS/ LCD_SEG13/ADC_IN19/ COMP1_INP/TIM9_CH1	34	SEG9									25	
PB14	SPI2_MISO/USART3_RT S/LCD_SEG14/ADC_IN20 /COMP1_INP/TIM9_CH2	35	SEG10									26	
PB15	SPI2_MOSI/TIM1_CH3N/ LCD_SEG15/ADC_IN21/ COMP1_INP/TIM11_CH1/ RTC_50_60Hz	36	SEG11									27	
PC0	ADC_IN10/LCD_SEG18/ COMP1_INP	8	SEG14									11	
PC1	ADC_IN11/LCD_SEG19/ COMP1_INP	9	SEG15									12	
PC2	ADC_IN12/LCD_SEG20/ COMP1_INP	10	SEG16									13	

Table 7. MCU pin description versus board function (continued)

MCU pin			Board function										
Main function	Alternate functions	LQFP 64 pin num.	LCD glass	Linear Touch Sensor	Push button	I _{DD}	LED	SWD	OSC	Free I/O	Power supply	P1	P2
PC3	ADC_IN13/LCD_SEG21/ COMP1_INP	11	SEG17									14	
PC4	ADC_IN14/LCD_SEG22/ COMP1_INP	24		PC4									
PC5	ADC_IN15/LCD_SEG23/ COMP1_INP	25		PC5									
PC6	TIM3_CH1/LCD_SEG24	37	SEG18										27
PC7	TIM3_CH2/LCD_SEG25	38	SEG19										26
PC8	TIM3_CH3/LCD_SEG26	39	SEG20										25
PC9	TIM3_CH4/LCD_SEG27	40	SEG21										24
PC10	USART3_TX/LCD_SEG28/ LCD_SEG40/LCD_COM4	51	SEG22										15
PC11	USART3_RX/LCD_SEG29/ LCD_SEG41/ LCD_COM5	52	SEG23										14
PC12	USART3_CK/LCD_SEG30/ LCD_SEG42/ LCD_COM6	53								X			13
PC13	RTC_AF1/WKUP2	2				CNT_EN						4	
PC14	OSC32_IN	3							OSC32_IN			5	
PC15	OSC32_OUT	4							OSC32_OUT			6	
PD2	TIM3_ETR/LCD_SEG31/ LCD_SEG43/LCD_COM7	54								X			12
OSC_IN	PH0	5							OSC_IN			7	
OSC_OUT	PH1	6							OSC_OUT			8	
-	-	-									GND	2	2
-	-	-									GND	9	5
-	-	-									GND	28	28
-	-	-									VDD	3	



6 Electrical schematics

Figure 13. STM32L-DISCOVERY

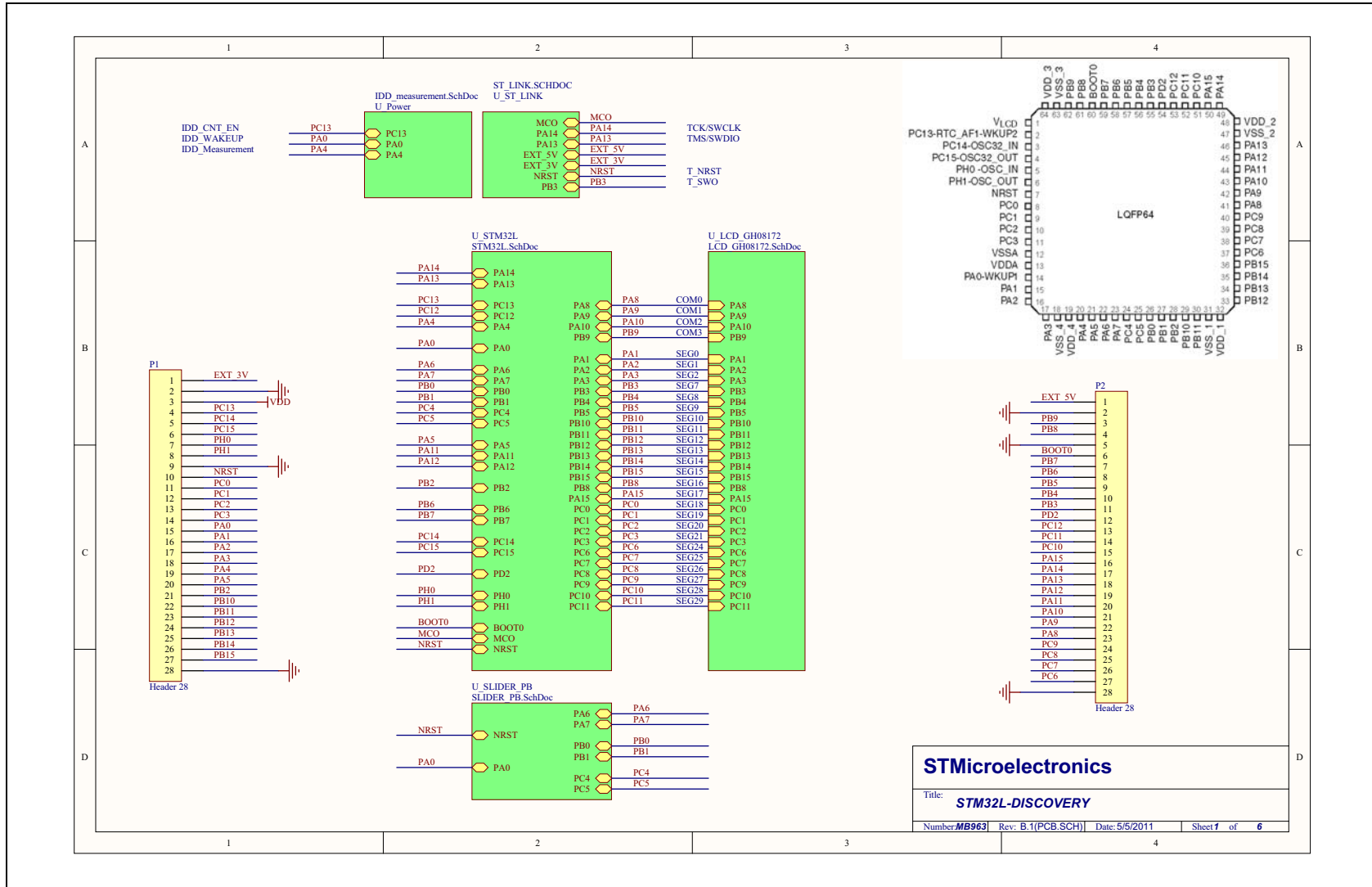



Figure 15. STM32L-DISCOVERY MCU

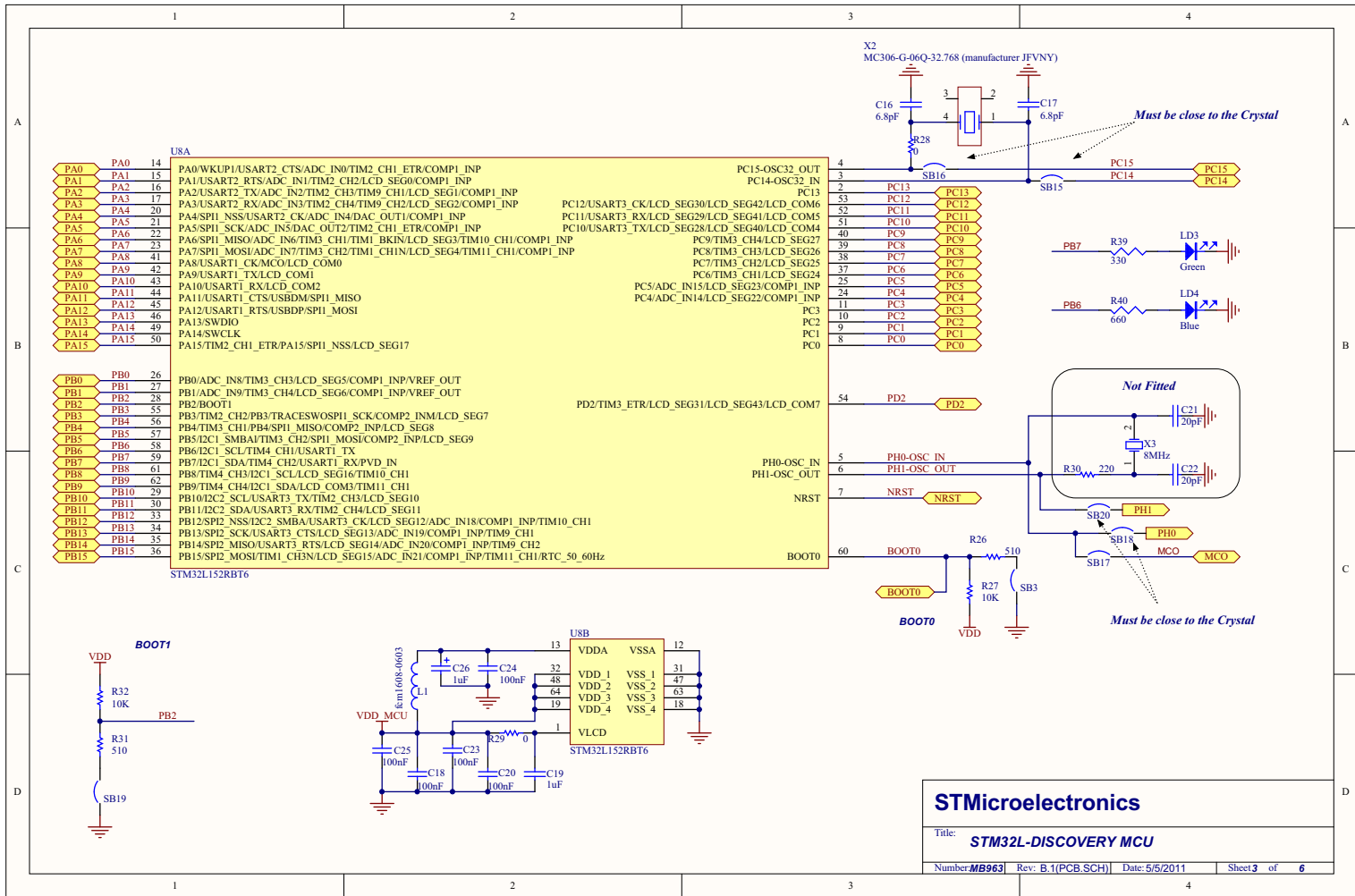



Figure 16. STM32L-DISCOVERY LCD

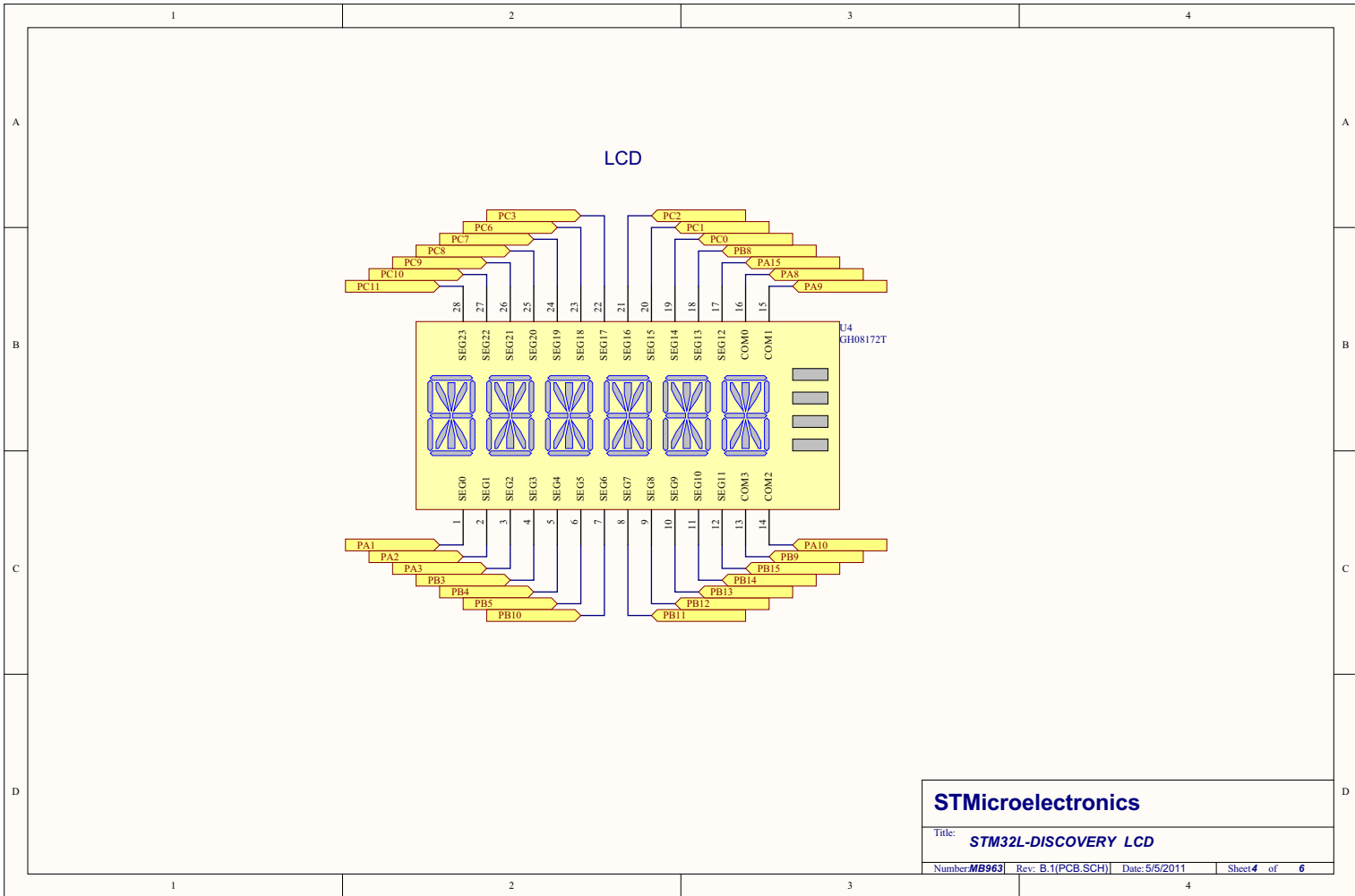
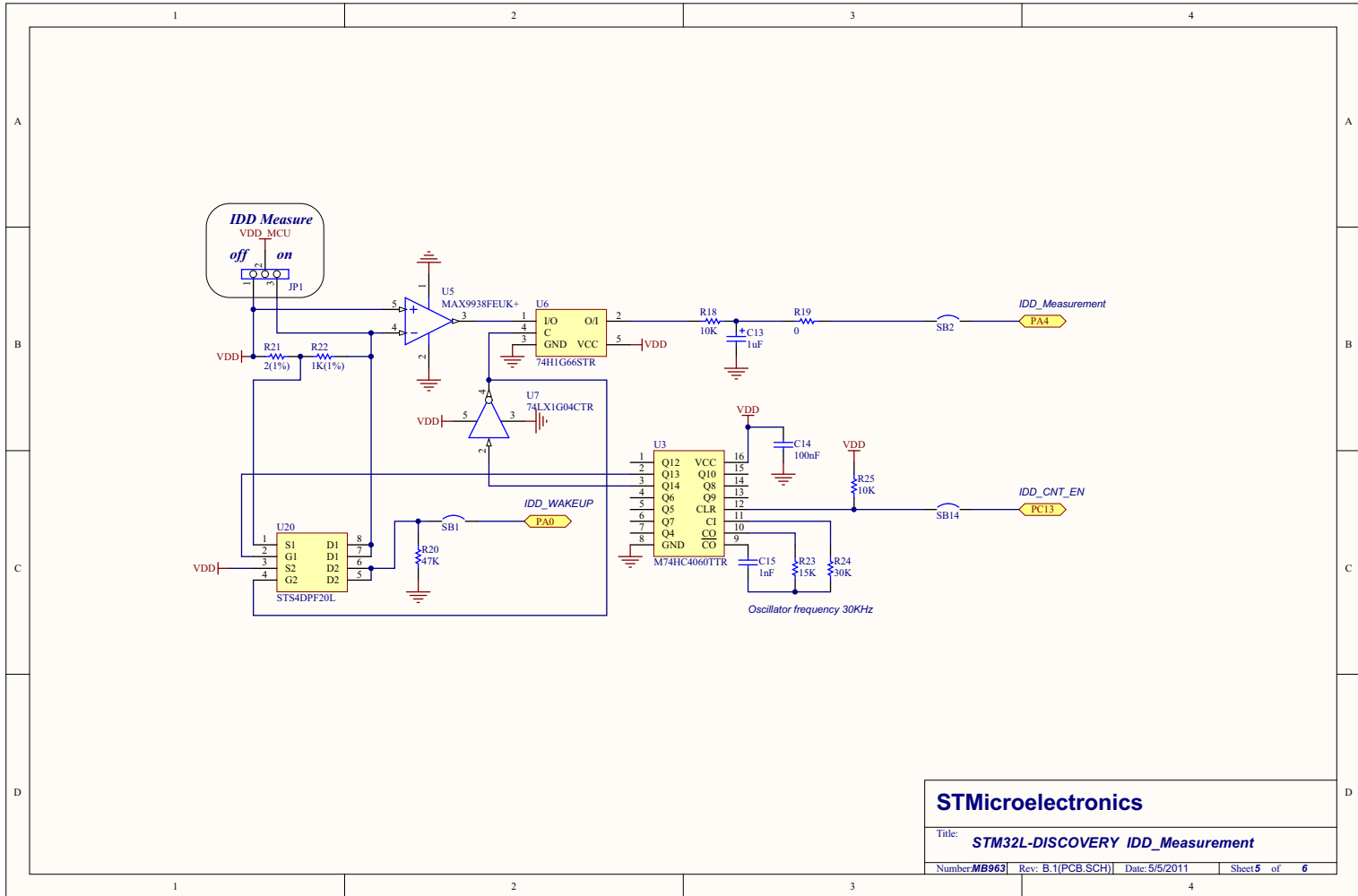



Figure 17. STM32L-DISCOVERY I_{DD} measurement



STMicroelectronics

Title: **STM32L-DISCOVERY IDD_Measurement**

Number **MB963** Rev: B.1(PCB.SCH) Date: 5/5/2011 Sheet **6** of **6**

Figure 18. STM32L-DISCOVERY linear touch sensor/touchkeys

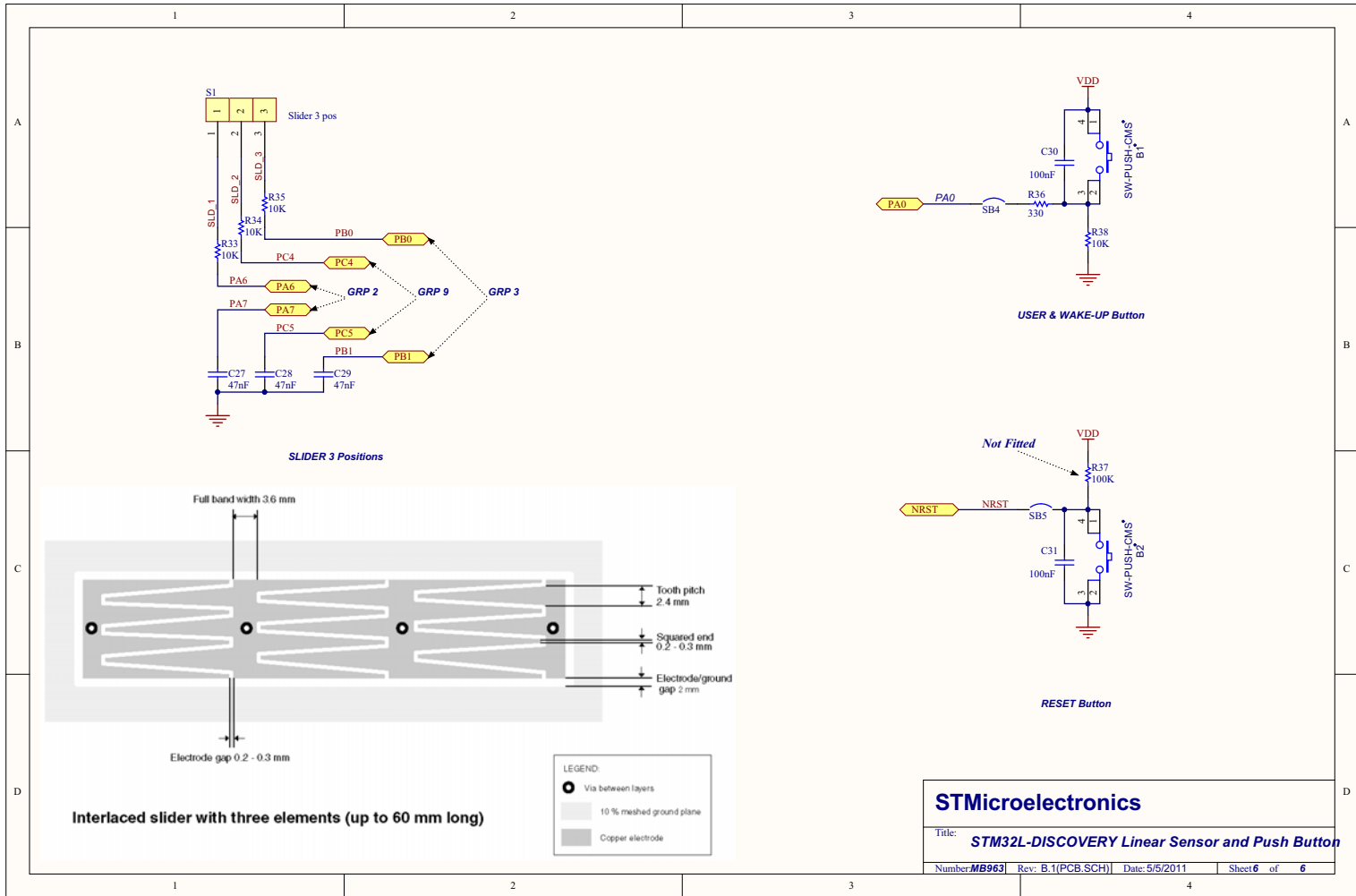

7 Revision history

Table 8. Document revision history

Date	Revision	Changes
13-May-2011	1	Initial release.

Please Read Carefully:

Information in this document is provided solely in connection with ST products. STMicroelectronics NV and its subsidiaries ("ST") reserve the right to make changes, corrections, modifications or improvements, to this document, and the products and services described herein at any time, without notice.

All ST products are sold pursuant to ST's terms and conditions of sale.

Purchasers are solely responsible for the choice, selection and use of the ST products and services described herein, and ST assumes no liability whatsoever relating to the choice, selection or use of the ST products and services described herein.

No license, express or implied, by estoppel or otherwise, to any intellectual property rights is granted under this document. If any part of this document refers to any third party products or services it shall not be deemed a license grant by ST for the use of such third party products or services, or any intellectual property contained therein or considered as a warranty covering the use in any manner whatsoever of such third party products or services or any intellectual property contained therein.

UNLESS OTHERWISE SET FORTH IN ST'S TERMS AND CONDITIONS OF SALE ST DISCLAIMS ANY EXPRESS OR IMPLIED WARRANTY WITH RESPECT TO THE USE AND/OR SALE OF ST PRODUCTS INCLUDING WITHOUT LIMITATION IMPLIED WARRANTIES OF MERCHANTABILITY, FITNESS FOR A PARTICULAR PURPOSE (AND THEIR EQUIVALENTS UNDER THE LAWS OF ANY JURISDICTION), OR INFRINGEMENT OF ANY PATENT, COPYRIGHT OR OTHER INTELLECTUAL PROPERTY RIGHT.

UNLESS EXPRESSLY APPROVED IN WRITING BY AN AUTHORIZED ST REPRESENTATIVE, ST PRODUCTS ARE NOT RECOMMENDED, AUTHORIZED OR WARRANTED FOR USE IN MILITARY, AIR CRAFT, SPACE, LIFE SAVING, OR LIFE SUSTAINING APPLICATIONS, NOR IN PRODUCTS OR SYSTEMS WHERE FAILURE OR MALFUNCTION MAY RESULT IN PERSONAL INJURY, DEATH, OR SEVERE PROPERTY OR ENVIRONMENTAL DAMAGE. ST PRODUCTS WHICH ARE NOT SPECIFIED AS "AUTOMOTIVE GRADE" MAY ONLY BE USED IN AUTOMOTIVE APPLICATIONS AT USER'S OWN RISK.

Resale of ST products with provisions different from the statements and/or technical features set forth in this document shall immediately void any warranty granted by ST for the ST product or service described herein and shall not create or extend in any manner whatsoever, any liability of ST.

ST and the ST logo are trademarks or registered trademarks of ST in various countries.

Information in this document supersedes and replaces all information previously supplied.

The ST logo is a registered trademark of STMicroelectronics. All other names are the property of their respective owners.

© 2011 STMicroelectronics - All rights reserved

STMicroelectronics group of companies

Australia - Belgium - Brazil - Canada - China - Czech Republic - Finland - France - Germany - Hong Kong - India - Israel - Italy - Japan - Malaysia - Malta - Morocco - Philippines - Singapore - Spain - Sweden - Switzerland - United Kingdom - United States of America

www.st.com